

EDB8250UE
00393658

Lenze

Operating Instructions

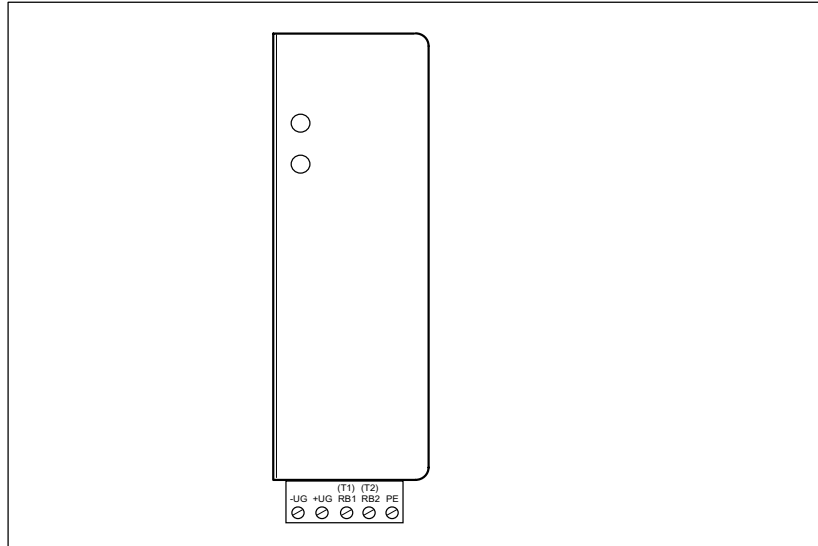

Brake unit
8250 series

These Operating Instructions are valid for brake units with the following nameplate data:

825X E 0x

(8251 - 8253)

In connection with the unit series as from the nameplate data:

820X E. xx. xx.

(8201 - 8204)

821X E. xx. xx.

(8211 - 8218)

Type	820X	E.	xx.	xx.	(8201 - 8204)
Design: E = Enclosure IP20 IB = Module	821X	E.	xx.	xx.	(8211 - 8218)
Hardware level and index					
Software level and index					
Variant					
Explanation					

Corresponds to the German edition of: 15/10/1996			
		revised:	
Edition of:	09/12/1996	31/01/1997	

Pos.	Name/Meaning	Note
1	Brake unit	<ul style="list-style-type: none"> ● 8251/8252 brake module ● 8253 brake chopper
2	LED	Display of the operating state <ul style="list-style-type: none"> ● green: <ul style="list-style-type: none"> - flashing, when voltage is applied to terminals + U_G, -U_G ● yellow: <ul style="list-style-type: none"> - flashing, when brake unit is in braking operation - Display of faults: see chapter 6, page 6-1
3	Connections	<ul style="list-style-type: none"> ● Voltage link: + U_G, -U_G only ● 8251/8252 brake module: ● Thermostat: T1, T2 only ● 8253 brake chopper: ● Brake resistor: RB1, RB2

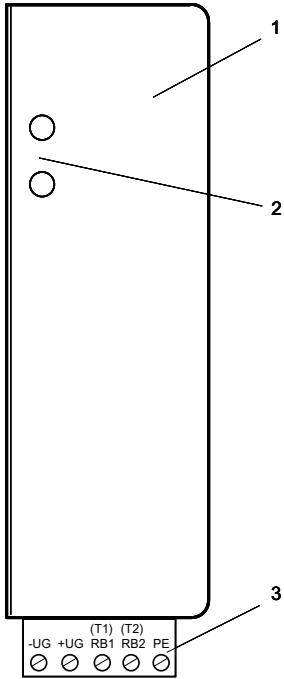



Safety and application notes for controllers

(according to: Low-Voltage Directive 73/23/EEC)

1. General

During operation, drive controllers may have, according to their type of protection, live, bare, in some cases also movable or rotating parts as well as hot surfaces.

Unauthorized removal of the required cover, inappropriate use, incorrect installation or operation, creates the risk of severe personal injury or damage to material assets.

Further information can be obtained from the documentation.

All operations concerning transport, installation, and commissioning as well as maintenance must be carried out by qualified, skilled personnel (IEC 364 and CENELEC HD 384 or DIN VDE 0100 and IEC report 664 or DIN VDE 0110 and national regulations for the prevention of accidents must be observed).

Qualified skilled personnel according to this basic safety information are persons who are familiar with the erection, assembly, commissioning, and operation of the product and who have the qualifications necessary for their occupation.

2. Application as directed

Drive controllers are components which are designed for installation in electrical systems or machinery.

When installing in machines, commissioning of the drive controllers (i.e. the starting of operation as directed) is prohibited until it is proven that the machine corresponds to the regulations of the EC Directive 89/392/EWG (Machinery Directive); EN 60204 must be observed.

Commissioning (i.e. starting of operation as directed) is only allowed when there is compliance with the EMC Directive (89/336/EWG).

The drive controllers meet the requirements of the Low-Voltage Directive 73/23/EWG. The harmonized standards of the prEN 50178/ DIN VDE 0160 series together with EN 60439-1/DIN VDE 0660 part 500 and EN 60146/DIN VDE 0558 are applicable to drive controllers.

The technical data and information on the connection conditions must be obtained from the nameplate and the documentation and must be observed in all cases.

3. Transport, storage

Notes on transport, storage and appropriate handling must be observed. Climatic conditions must be observed according to prEN 50178.

4. Erection

The devices must be erected and cooled according to the regulations of the corresponding documentation.

The drive controllers must be protected from inappropriate loads. Particularly during transport and handling, components must not be bent and/or isolating distances must not be changed. Touching of electronic components and contacts must be avoided.

Drive controllers contain electrostatically sensitive components which can easily be damaged by inappropriate handling. Electrical components must not be damaged or destroyed mechanically (health risks are possible!).

5. Electrical connection

When working on live drive controllers the valid national regulations for the prevention of accidents (e.g. VBG 4) must be observed.

The electrical installation must be carried out according to the appropriate regulations (e.g. cable cross-sections, fuses, PE connection). More detailed information is included in the documentation.

Notes concerning the installation in compliance with EMC - such as screening, grounding, arrangement of filters and laying of cables - are included in the documentation of the drive controllers. These notes must also be observed in all cases for drive controllers with the CE mark. The compliance with the required limit values demanded by the EMC legislation is in the responsibility of the manufacturer of the system or machine.

6. Operation

Systems where drive controllers are installed must be equipped, if necessary, with additional monitoring and protective devices according to the valid safety regulations, e.g. law on technical tools, regulations for the prevention of accidents, etc. Modifications of the drive controllers by the operating software are allowed.

After disconnecting the drive controllers from the supply voltage, live parts of the controller and power connections must not be touched immediately, because of possibly charged capacitors. For this, observe the corresponding labels on the drive controllers.

During operation, all covers and doors must be closed.

7. Maintenance and servicing

The manufacturer's documentation must be observed.

This safety information must be preserved!

The product-specific safety and application notes in these operating instructions must also be observed!

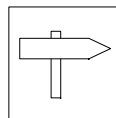

1	Preface and general information	1-1
1.1	About these Operating Instructions	1-1
1.1.1	Terminology used	1-1
1.2	Scope of delivery	1-2
1.3	825X brake units	1-2
1.3.1	Labelling	1-2
1.3.2	Application as directed	1-3
1.3.3	Legal regulations	1-4
2	Safety information	2-1
2.1	Personnel responsible for safety	2-1
2.2	General safety information	2-2
2.3	Layout of the safety information	2-3
2.4	Residual hazards	2-4
3	Technical data	3-1
3.1	Features	3-1
3.2	General data /operating conditions	3-2
3.3	Rated data	3-3
3.3.1	Brake units	3-3
3.3.2	Assignment table for brake resistors	3-3
3.3.3	Overcurrent relay and cable cross-sections	3-4
3.4	Dimensions	3-4
4	Installation	4-1
4.1	Mechanical installation	4-1
4.1.1	Important notes	4-1
4.1.2	Standard assembly with fixing rail	4-2
4.1.3	DIN-rail assembly	4-3
4.2	Electrical installation	4-4
4.2.1	Operator's safety	4-4
4.2.2	Protection of the brake unit	4-5
4.2.3	Specification of cables used	4-5
4.3	Connection	4-6
4.3.1	Power connection	4-6
4.3.2	8251 brake module on 820X controller	4-7
4.3.3	8252 brake module on 821X controller	4-8
4.3.4	8253 brake chopper on 821X controller	4-9
4.3.5	Connect temperature monitoring	4-10

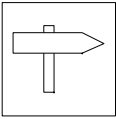

Contents

5	Commissioning	5-1
6	Troubleshooting and fault elimination	6-1
7	Waste disposal	7-1
8	Supplement	8-1
8.1	Accessories	8-1
8.1.1	Brake resistors	8-1
8.2	EC Directives/Declaration of Conformity	8-3
8.2.1	What is the purpose of EC directives?	8-3
8.2.2	What does the CE mark imply?	8-3
8.2.3	EC Low-Voltage Directive	8-4
8.2.4	EC Machinery Directive	8-6
8.3	Glossary	8-8
	Index	8-9



1 Preface and general information

1.1 About these Operating Instructions ...

- The present Operating Instructions are used for operations concerning safety measures on and with the 825X brake units. They contain safety information which must be observed.
- All persons who work on and with 825X brake units must have the Operating Instructions available and observe all relevant notes and instructions.
- The Operating Instructions must always be in a complete and perfectly readable state.

1.1.1 Terminology used

Brake unit

The "8251 brake module", the "8252 brake module" or the "8253 brake chopper with brake resistor" are called "brake unit" in the following text.

Controller

In the following text, the term "controller" is used for "82XX frequency inverter".

Drive system

For drive systems with 825X brake units and other Lenze drive components, the term "drive system" is used in the following text.



1.2 Scope of delivery

- The scope of delivery includes:
 - 1 8251 brake module, 1 8252 brake module or 1 8253 brake chopper
 - 1 push-on terminal strip
 - 1 accessory kit with fixing material
 - 1 book of Operating Instructions
- After reception of the delivery, check immediately whether the scope of supply matches the accompanying papers. Lenze does not accept any liability for deficiencies claimed subsequently. Claim
 - visible transport damage immediately to the forwarder.
 - visible deficiencies/incompleteness immediately to your Lenze representative.

1.3 825X brake units

1.3.1 Labelling

- Lenze 825X brake units are clearly identified by the indications on the nameplate.
- CE mark
 - Conformity with the EC Low-Voltage Directive
 - Conformity with the EC Electromagnetic-Compatibility Directive in preparation
- Manufacturer:
 - Lenze GmbH & Co KG
Postfach 101352
D-31763 Hameln



1.3.2 Application as directed

8251 brake modules

- Additional units for Lenze controllers:
 - 820X frequency inverters (8201 to 8204)

8252 brake modules and 8253 brake choppers

- Additional units for Lenze controllers:
 - 821X frequency inverters (8211 to 8218)

825X brake units

- Operate the brake units only under the conditions prescribed in these Operating Instructions.
- They are components
 - for installation in a machine
 - for assembly with other components to form a machine.
- They are electrical equipment for installation into control cabinets or similar closed operating rooms.
- They meet the protection requirements of the EC Low-Voltage Directive.
- They are not machinery in the sense of the EC Machinery Directive.
- They are not household appliances but are intended exclusively as components for further commercial use.

Drive systems with 825X brake units

- They correspond to the EC Electromagnetic Compatibility Directive if they are installed according to the guidelines of CE-typical drive systems.
- They can be operated
 - on public and non-public mains.
 - in industrial as well as residential and commercial premises.
- The compliance with the EC Directives in machine application is in the responsibility of the user.

Any other use shall be deemed inappropriate!



Preface and general information

1.3.3 Legal regulations

Liability

- The information, data, and notes in these Operating Instructions met the state of the art at the time of printing. Claims referring to drive systems which have already been supplied cannot be derived from the information, illustrations, and descriptions.
- The specifications, processes, and circuitry described in these Operating Instructions are for guidance only and must be adapted to your own specific application. Lenze does not take responsibility for the suitability of the process and circuit proposals.
- The indications given in these Operating Instructions describe the features of the product without warranting them.
- Lenze does not accept any liability for damage and operating interference caused by:
 - Disregarding these Operating instructions
 - Unauthorized changes of the brake units
 - Operating mistakes
 - Improper working on and with the brake units

Warranty

- Terms of warranty: see terms of sale and delivery of Lenze GmbH & Co KG.
- Warranty claims must be made to Lenze immediately after detecting the deficiency or fault.
- The warranty is void in all cases where liability claims cannot be made.



2 Safety information

2.1 Personnel responsible for safety

Operator

- An operator is any natural or legal person who uses the drive system or on behalf of whom the drive system is used.
- The operator or his safety officer are obliged
 - to check whether all relevant regulations, notes, and laws are observed.
 - to ensure that only qualified personnel work with and on the drive system.
 - to ensure that the personnel have the Operating Instructions available for all corresponding operations
 - to prohibit non-qualified personnel from working with and on the drive system.

Qualified personnel

Qualified personnel are persons who are - because of their education, experience, instructions, and knowledge about corresponding standards and regulations, rules for the prevention of accidents, and operating conditions - authorized by the person responsible for the safety of the plant to perform the required actions and who are able to recognize and avoid potential hazards. (see IEC 364, definition of qualified personnel)



2.2 General safety information

- This safety information is not claimed to be complete. In case of questions and problems please contact your Lenze representative.
- At the time of delivery the brake unit meets the state of the art and ensures basically safe operation.
- The indications given in these Operating Instructions refer to the stated versions of the brake unit.
- The brake unit is hazardous for persons, the brake unit itself and other property of the operator, if
 - non-qualified personnel work with and on the brake unit.
 - the brake unit is not used as directed.
- The specifications, processes, and circuitry described in these Operating Instructions are for guidance only and must be adapted to your own specific application.
- Brake units must be designed so that they comply with their function and do not cause any hazards for persons under the conditions of correct installation and faultless operation as instructed. This is also effective for the interaction with the complete plant.
- Take additional measures to limit consequences of malfunctions which may cause hazards for persons or material assets:
 - Further independent equipment which can take over the function of the brake unit
 - Electrical or non-electrical protection (latching or mechanical blocking)
 - Measures covering the complete system
- Operate the drive system only in a perfect condition.
- Changes or retrofittings to the brake unit are prohibited in principle. In any case, Lenze must be contacted.



2.3 Layout of the safety information

- All safety information in these Operating Instructions has a uniform layout:



Danger

Note

- The icon designates the type of danger.
- The signal word designates the severity of danger.
- The note describes the danger and suggests how to avoid the danger.

Warning of danger for persons

Icons used		Signal words	
	Warning of hazardous electrical voltage	Danger!	Warns of impending danger . Consequences if disregarded: Death or very severe injuries.
		Warning!	Warns of potential, very hazardous situations . Possible consequences if disregarded: Death or very severe injuries.
	Warning of a general danger	Caution!	Warns of potential, hazardous situations . Possible consequences if disregarded: Light or minor injuries.

Warning of material damage

Icons used		Signal words	
		Stop!	Warns of possible material damage . Possible consequences if disregarded: Damage to the drive system or its environment.

Other notes

Icons used		Signal words	
		Note!	Designates a general, useful tip. If you observe it, handling of the drive system is made easier.



2.4 Residual hazards

Protection of persons

After mains voltage disconnection the power terminals $+U_G$, $-U_G$ remain live for 3 minutes.

Brake units may have surface temperatures of up to 130°C for up to 30 minutes after mains disconnection.

Touching the brake unit may cause burns.

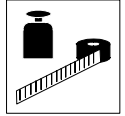

3 Technical data

3.1 Features

- Three types:
 - 8251 brake module with internal brake resistor for frequent braking operations with low load or infrequent braking with medium load for operation with 820X frequency inverter
 - 8252 brake module with internal brake resistor for frequent braking operations with low load or infrequent braking with medium load for operation with 8211- 8213 frequency inverters
 - 8253 brake chopper with external brake resistor for high-load continuous braking for operation with 821X frequency inverter
- Conversion of the mechanical braking energy into thermal energy
 - Controller does not set pulse inhibit during braking, i.e. the braking operation still remains controlled
- Very short braking times are possible
- Enclosure IP10 for installation in a control cabinet
- DIN-rail assembly possible (additional accessories required)
- Fixed thresholds for the mains voltages 230 V (8251) and 400...460 V (8252/8253)
- Current-state display via LED



Technical Data

3.2 General data /operating conditions

Field	Values
Vibration resistance	Germanischer Lloyd, general conditions (in preparation)
Permissible moisture	Humidity class F without condensation (medium relative humidity 85 %)
Permissible temperature ranges	during transport : -25 °C ... +70 °C during storage: -25 °C ... +70 °C during operation: 0 °C ...+40 °C
Permissible installation height h	$h \leq 1000$ m a.m.s.l. without power derating 1000 m a.m.s.l < $h \leq 4000$ m a.m.s.l with power derating
Degree of pollution	VDE 0110 part 2 pollution degree 2
Insulation strength	Overvoltage category III according to VDE 0110
Packing	to DIN 4180
Type of protection	IP10 NEMA 1: Protection against contact
Approvals	CE: Low-Voltage Directive EMC Directive in preparation

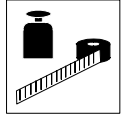

3.3 Rated data

3.3.1 Brake units

Type	EMB8251-E	EMB8252-E	EMB8253-E
Order no.	EMB8251-E	EMB8252-E	EMB8253-E
Supply voltage V_N	270 ... 400 V DC	270 ... 750 V DC	270 ... 750 V DC
Threshold V_Z	375 V DC	725 V DC	725 V DC
Peak current	5.4 A DC	2.7 A DC	15 A DC
Max. continuous current	0.2 A DC	0.1 A DC	7.5 A DC
Peak braking power at V_Z	2 kW ¹⁾	2 kW ¹⁾	11.2 kW ²⁾
Continuous braking power at V_Z	70 W	70 W	5.6 kW
Min. brake resistance	(internal resistor)	(internal resistor)	47 $\Omega \pm 10\%$
Max. energy (min. 5 min break)	20 kWs	20 kWs	(external resistor)
Power derating	40 °C < T < 50 °C: 2%/K 1000 m a.m.s.l. < h < 4000 m a.m.s.l.: 5%/1000 m		
Weight	1.3 kg	1.3 kg	1.1 kg

- 1) max. 10 s with switch-on cycle 3 %
- 2) max. 60 s with switch-on cycle 50 %

3.3.2 Assignment table for brake resistors

The assignment depends on the motor power and is effective up to the indicated limit value.

Motor power kW	Recommended Lenze brake resistor			
	Order no.	Resistor Ω	Peak braking power kW	Thermal capacity kWs
< 0.75	ERBM470R100W	470	1.0	15
< 1.5	ERBM370R150W	370	1.5	22,5
< 2.2	ERBM240R200W	240	2.0	30
< 3.0	ERBD180R300W	180	3.0	45
< 4.0	ERBD100R600W	100	5.5	90
< 5.5	ERBD082R600W	82	6.5	90
< 7.5	ERBD068R800W	68	8.0	120
< 11.0	ERBD047R01K2	47	11.5	180

The resistors are designed for a cycle of:

- max. 15 s braking at peak braking power
- min. 150 s release time after braking



3.3.3 Overcurrent relay and cable cross-sections

With a cable cross section of the feeding inverter of $> 2.5 \text{ mm}^2$ the cable can be protected via overcurrent relay.

The cable cross-sections used must meet the valid regulations. We recommend:

Type	Input + UG, -UG	
	Overcurrent relay [A]	Cable cross-section [mm ²]
8251	not required	1.5
8252	not required	1.5
8253	max 12 *	2.5

* depending on the brake resistor

3.4 Dimensions

The dimensions of the brake units depend on the mechanical installation (see chapter 4.1)

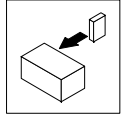

4 Installation

4.1 Mechanical installation

4.1.1 Important notes

- Use the brake units only as built-in devices!
- Observe free space!
 - Allow a free space of 100 mm at the top and at the bottom.
- Ensure unimpeded ventilation of cooling air and outlet of exhaust air.
- If the cooling air contains pollutants (dust, fluff, grease, aggressive gases), which may impair the function of the brake units:
 - Take suitable preventive measures , e.g. separate air duct, installation of filters, regular cleaning, etc.
- Do not exceed the permissible range of the operating ambient temperature (see chapter 3.2).
- If the brake units are permanently subjected to vibration or shaking:
 - Check whether shock absorbers are necessary.



Danger!

Operation with 8253 brake chopper and external brake resistor:

- In the event of failures, brake resistors can become very hot, they can even burn. E.g. when the following occurs:
 - mains overvoltage,
 - application-specific overload,
 - internal fault.
 - Brake resistors must therefore be installed such that the very high temperatures possible cannot cause any damage.
-

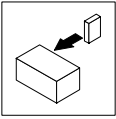

Installation

Possible mounting positions

- In vertical position at the backside of the control cabinet.
 - terminal strip at the bottom
 - assembled on attached fixing rail (see chapter 4.1.2) or DIN rail (see chapter 4.1.3)

4.1.2 Standard assembly with fixing rail

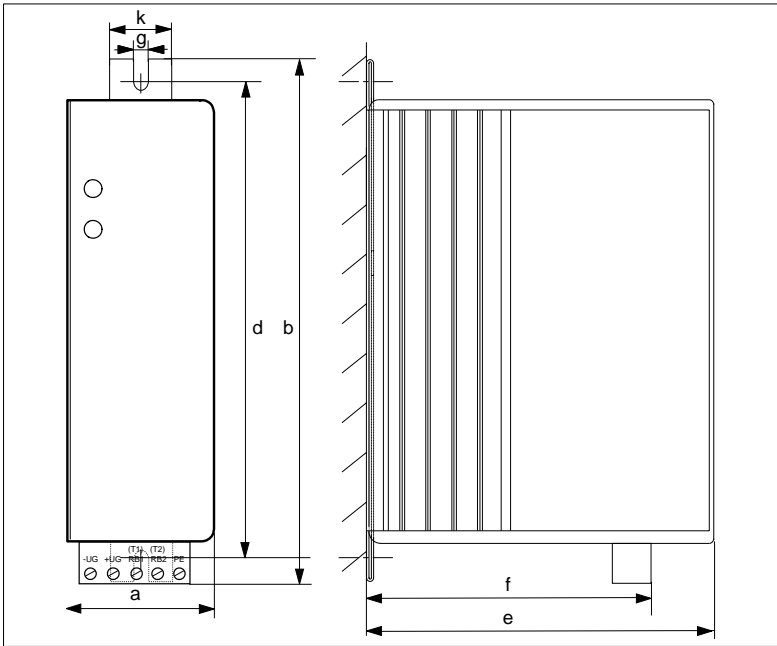
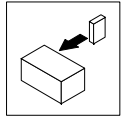

Fig. 4-1 Dimensions for fixing-rail assembly

Type	a	b	c	d	e	f	g	k
8251								
8252	56	210	28	190	170	130	6.5	30
8253								

All dimensions in mm



4.1.3 DIN-rail assembly

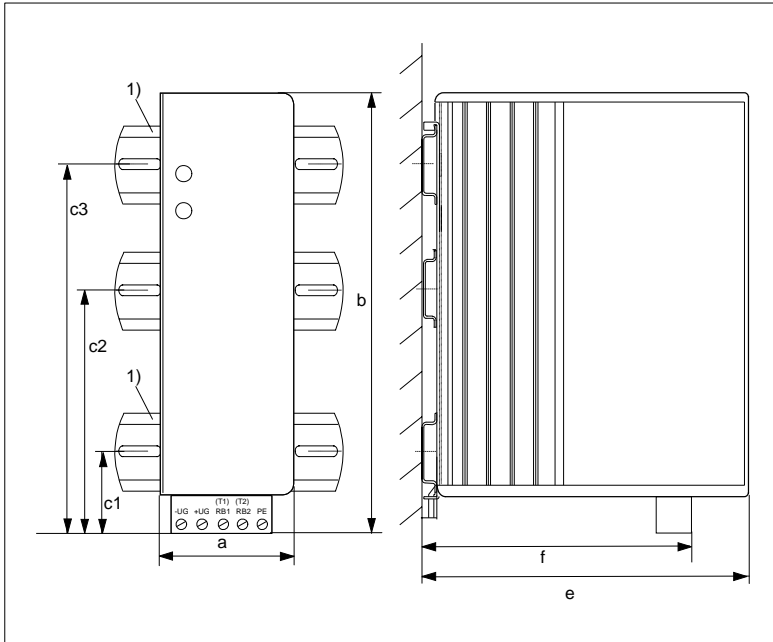
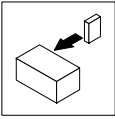

Fig. 4-2 Dimensions for DIN-rail assembly

1) Assembly with one DIN rail (in the middle) or with 2 DIN rails (top/bottom) possible.

Type	a	b	c ₁	c ₂	c ₃	e	f
8251	56	190	16	98	149	173	133
8252							
8253							



Installation

4.2 Electrical installation

4.2.1 Operator's safety



Danger!

After switching off the mains voltage, all power terminals (+U_G, -U_G and RB1, RB2) of the brake unit remain live for up to 3 minutes.

Therefore please wait for 3 minutes after having switched off the mains voltage before you start to work.

- For single drives, the brake unit carries a hazardous voltage up to three minutes after mains disconnection.
- In a drive network, all controllers must be inhibited and disconnected from the mains.



Danger!

During braking operation (e.g. test stand, high inertia loads etc.) the voltage is still present after mains switching (OFF).

It is therefore necessary to set all controllers to controller inhibit.

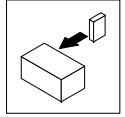

4.2.2 Protection of the brake unit



Stop!

The brake units contain electrostatically sensitive components.

- Prior to assembly and service operations, the personnel must be free of electrostatic charge:
 - They can discharge themselves by touching the PE fixing screw or another grounded metal part in the control cabinet.
-
- In the event of condensation connect the brake unit to mains voltage only after the visible humidity has evaporated.

4.2.3 Specification of cables used

- The cables used must comply with the approvals required at the site (eg. UL).
- The prescribed minimum cross-sections of PE conductors must be maintained in all cases. The cross-section of the PE conductor must be at least as large as the cross-section of the power connections (VDE 0160).
- The screening quality of a cable is determined by
 - a good screen connection
 - a low screen resistance
Use only screens with tin-plated or nickel-plated copper braid!
Screens of steel braid are not suitable.
 - the degree of coverage of the screen braid:
at least 70% to 80% with a coverage angle of 90°



Note!

The screens are only required to comply with existing standards (e.g. VDE 0160, EN 50178).

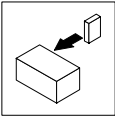

4.3 Connection

4.3.1 Power connection

- All indications about cable cross-sections are recommendations and refer to the application:
 - in control cabinets and machines
 - in cable ducts
 - at a max. ambient temperature +40 °C
- The compliance with other standards (e.g.: VDE 0113, VDE 0289, etc.) remains the responsibility of the user.
- The cables between brake unit and controller must not be longer than max. 2 m.
- If the brake unit is directly connected with the controller and the cable length does not exceed ≤ 0.5 m, the cables can be used as unshielded single cores.
- For a radio interference suppression (limit-value class A or B) to DIN 55011 observe the following:
 - The cables must be shielded.
 - For cable lengths up to 1 m it is sufficient to connect the shield at the middle.
 - For cable lengths > 1 m, the shield must always be connected on both sides.

Connection

- The cables between controller and brake unit must be DC-bus connected to the terminals +UG, -UG.
- Observe stud torques:

Terminals	0.5 ... 0.6 Nm
	4.4 ... 5.3 lbf·in

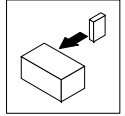

4.3.2 8251 brake module on 820X controller

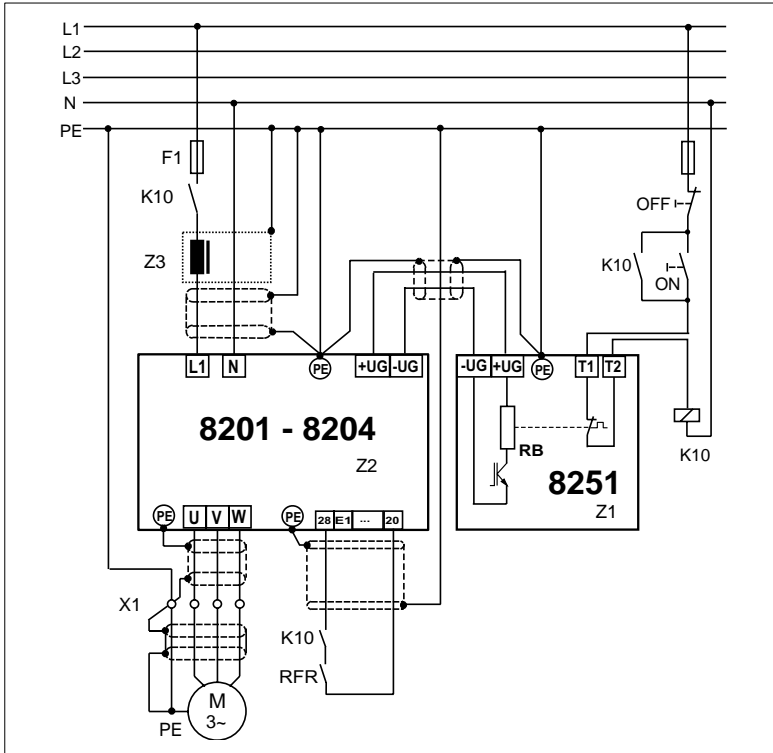
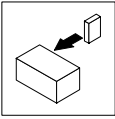

Fig. 4-3 Connection of 8251 brake module to 820X controller

- Z1: Brake module
- Z2: Controller
- Z3: Mains choke
- K10: Mains contactor
- F1: Mains fuse (recommended)



Installation

4.3.3 8252 brake module on 821X controller

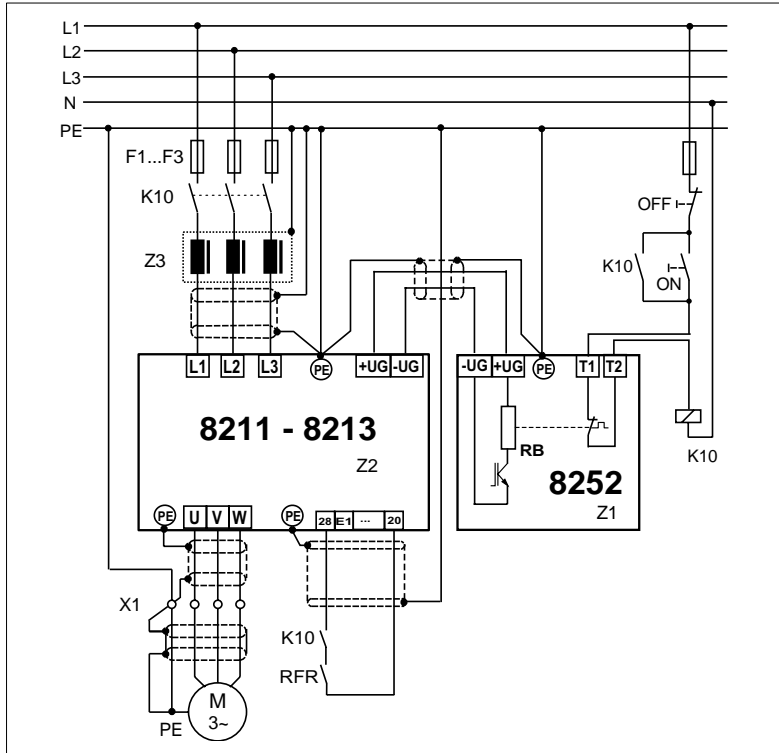
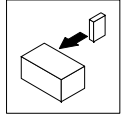

Fig. 4-4 Connection of 8252 brake module to 821X controller

- Z1: Brake module
- Z2: Controller
- Z3: Mains choke
- K10: Mains contactor
- F1 ... F3: Mains fuses (recommended)



4.3.4 8253 brake chopper on 821X controller

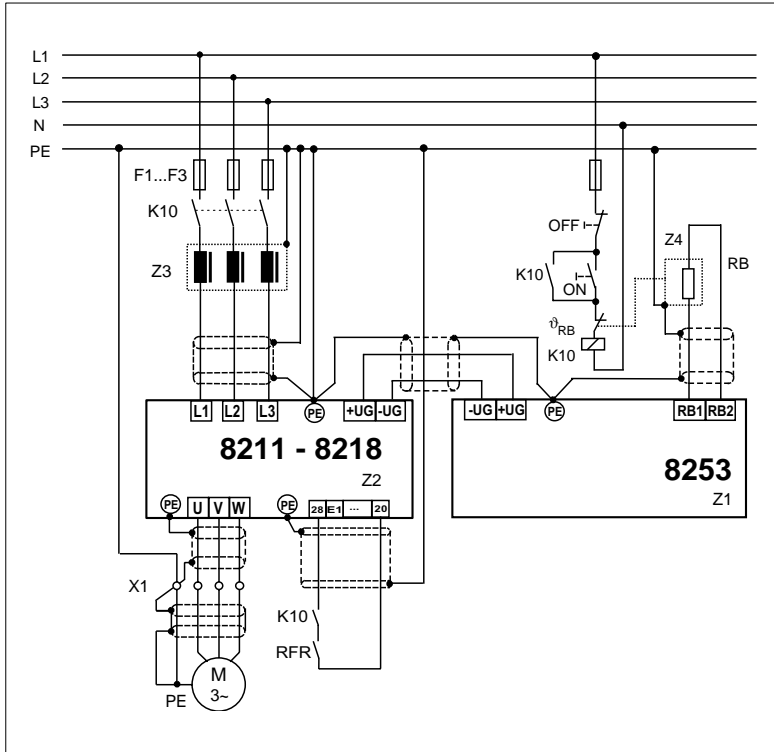
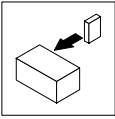

Fig. 4-5 Connection of 8253 brake chopper to 821X controller

- Z1: Brake chopper
- Z2: Controller
- Z3: Mains choke
- Z4: Brake resistor
- K10: Mains contactor
- F1 ... F3: Mains fuses (recommended)
- J_{RB}: Thermal overcurrent release
- RB: Brake resistor



Installation

4.3.5 Connect temperature monitoring



Danger!

The temperature monitoring is required to ensure safe switch-off in the event of a failure.

Use the thermostats of the brake resistors to

- separate the controller from the mains if the temperature monitoring is activated

- set controller inhibit in all connected controllers.

For connection of the thermostat: see the corresponding signal-flow diagrams (chapter 4.3.2 ... 4.3.4).

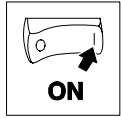

5 Commissioning



Stop!

If the connections $+U_G$ and $-U_G$ are reserved, the brake units and all connected components can be destroyed.

It is therefore absolutely necessary to check the correct connection of the terminals before switching on the unit.

The two LEDs at the brake unit indicate the operating state:

- green LED:
illuminated, when the brake unit is supplied with voltage and is ready for operation
- yellow LED:
illuminated, when brake unit is in braking operation



Note!

The deceleration time of the drive will be prolonged if the feedback power is higher than the peak brake power of the assigned brake resistor. In this case, the controller sets pulse inhibit and indicates „overvoltage“.

Prolong the T_{if} -time via the deceleration ramp at the ramp-function generator or the QSP ramp at the controller or use a lower-value brake resistor, if permitted.



Commissioning



6 Troubleshooting and fault elimination

Fault	Cause	Remedy
Green LED is not illuminated	No voltage at terminals + U _G , -U _G	<ul style="list-style-type: none"> • Switch on the mains • Connect the brake unit to the terminals + U_G, -U_G of the controller
Controller sets pulse inhibit during braking and indicates overvoltage	The brake unit is not connected to the terminals + U _G , -U _G of the controller	Connect the brake unit to the terminals + U _G , -U _G of the controller
<ul style="list-style-type: none"> • Yellow LED is not illuminated 		
<ul style="list-style-type: none"> • Yellow LED is illuminated 		
	Brake resistor is not connected	Connect brake resistor
	Brake resistance too high	Use lower-value brake resistor



Troubleshooting and fault elimination



7 Waste disposal

The brake unit consists of different materials.

The following table indicates which materials must be recycled and which require separate disposal.

Material	recycle	dispose
Metal	x	-
Plastic	x	-
Printed-board assemblies	-	x
Operating Instructions	x	-



Waste disposal

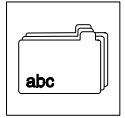

8 Supplement

8.1 Accessories

8.1.1 Brake resistors

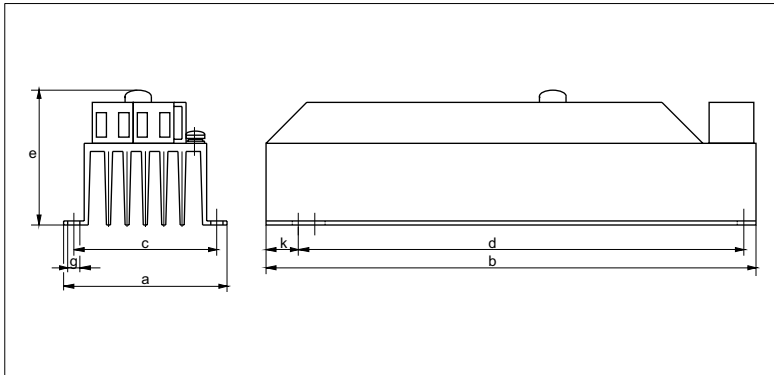
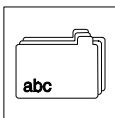

Fig. 8-1 Brake modules with integrated temperature monitoring

Resistance Ω	Order no.	Rated power W	a mm	b mm	c mm	d mm	e mm	g mm	k mm
470	ERBM470R100W	100	70	240	50	225	60	5	7.5
370	ERBM370R150W	150	80	240	70	225	95	5	7.5
200	ERBM240R200W	200	80	340	70	325	70	5	7.5



Appendix

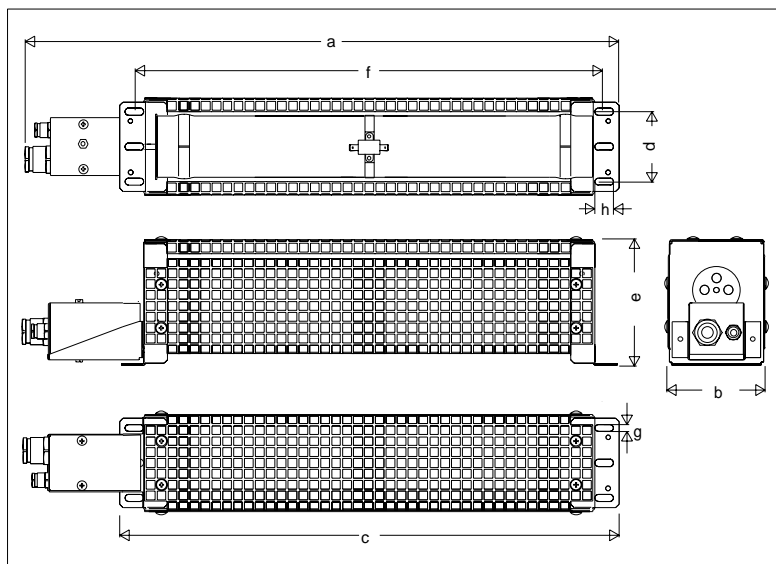
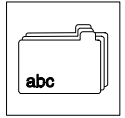

Fig. 8-2 Grid protected wire resistors

Brake resistor		Dimensions							
Resistance Ω	Order no.	a mm	b mm	c mm	d mm	e mm	f mm	g mm	h mm
180	ERBD180R300W	440	89	354	64	115	326	6.5	13
100	ERBD100R600W	640	89	530	64	115	426	6.5	13
82	ERBD082R600W	640	89	554	64	115	526	6.5	13
68	ERBD068R800W	540	177	454	150	115	426	6.5	13
47	ERBD047R01K2	640	177	554	150	115	526	6.5	13



8.2 EC Directives/Declaration of Conformity

8.2.1 What is the purpose of EC directives?

EC directives are issued by the European Council and are intended for the determination of common technical requirements (harmonization) and certification procedures within the European Community. At the moment, there are 21 EC directives of product ranges. The directives are or will be converted to national laws of the member states. A certification issued by one member state is valid automatically without any further approval in all other member states.

The texts of the directive are restricted to the essential requirements. Technical details are or will be determined by European harmonized standards.

8.2.2 What does the CE mark imply?

After a verification, the conformity according to the EC directives is certified by affixing a CE mark. Within the EC there are no commercial barriers for a product with the CE mark.

Controllers on their own with the CE mark exclusively correspond to the Low-Voltage Directive. For the compliance with the EMC Directive, recommendations are given.



8.2.3 EC Low-Voltage Directive

(73/23/EEC)

amended by: CE Mark Directive (93/68/EEC)

General

- The Low-Voltage Directive is effective for all electrical equipment for use with a rated voltage between 50 V and 1000 V AC and between 75 and 1500 V DC and with normal ambient conditions. The use of e.g. electrical equipment in explosive atmospheres and electrical parts in passenger and goods lifts are excepted.
- The objective of the Low-Voltage Directive is to ensure that only electrical equipment which does not endanger the safety of persons or animals is placed on the market. It should also be designed to conserve material assets.



EC Declaration of Conformity '96

for the purpose of the EC Low-Voltage Directive(73/23/EEC)

amended by: CE Mark Directive (93/68/EEC)

The 8251 and 8252 brake modules are developed, designed, and manufactured in compliance with the above mentioned EC Directive under the sole responsibility of

Lenze GmbH & Co KG, Postfach 10 13 52, D-31763 Hameln

Standards considered:

Standard	
DIN VDE 0160 5.88 + A1 / 4.89 + A2 / 10.88 prDIN EN 50178 Classification VDE 0160 / 11.94	Electronic equipment for use in electrical power installations
DIN VDE 0100	Standards for the installation of power installations
EN 60529	IP Degrees of protection
IEC 249 / 1 10/86, IEC 249 / 2-15 / 12/89	Base material for printed circuits
IEC 326 / 1 10/90, EN 60097 / 9.93	Printed circuits, printed boards
DIN VDE 0110 /1-2 /1/89 /20/ 8/90	Creepage distances and clearances

Hameln, 01 August, 1996

(i. V. Loy)

Product Manager



Appendix

8.2.4 EC Machinery Directive

(89/392/EEC)

amended by: First Amendment Directive (91/368/EEC)
 Second Amendment Directive (93/44/EEC)
 CE Mark Directive (93/68/EEC)

General

For the purpose of the Machinery Directive, "machinery" means an assembly of linked parts or components, at least one of which moves, with the appropriate actuators, control and power circuits, etc., joined together for a specific application, in particular for the processing, treatment, moving or packaging of a material.

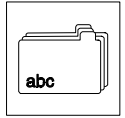

EC Manufacturer's Declaration

for the purpose of the EC Machinery Directive (89/392/EEC)

amended by: First Amendment Directive (91/368/EEC)
 Second Amendment Directive (93/44/EEC)
 CE Mark Directive (93/68/EEC)

The 8251, 8252 brake modules and the 8253 brake chopper were developed, designed, and manufactured under the sole responsibility of

Lenze GmbH & Co KG, Postfach 10 13 52, D-31763 Hameln

Commissioning of the 8251, 8252 brake modules and the 8253 brake chopper is prohibited until it is proven that the machine where they are to be installed corresponds to the EC Machinery Directive.

Hameln, 01 August, 1996

(i. V. Loy)

Product Manager

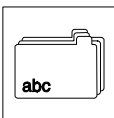

Appendix

8.3 Glossary

Term	Meaning
Controller	General name for servo drives (93XX), frequency inverters (82XX, 86XX) and DC drives (48XX, 49XX)
Icon	Sign or symbol with an unambiguous message.
IMP	Pulse inhibit
Peak brake power	Maximum power which can be converted into heat by a resistor
PTC	PTC thermistor (PTC: positive temperature coefficient)
RB	Brake resistor
Residual hazards	Hazards which cannot be eliminated by design
Use	Appropriate: Appropriate use of the machine according to the manufacturer's information or to common use according to its design and function. Inappropriate: Any other use which is not instructed.

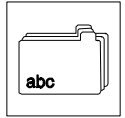

A

Accessories, 8-1

B

Brake resistors, 8-1
Brake unit, 1-1, 1-2
Brake module 8251/8252, 1-2
Brake chopper 8253 , 1-2

C

Cable specification, 4-5
Commissioning, 5-1
Connection, 4-6
Controller, 1-1
 Application as directed, 1-3
 Labelling, 1-2

D

Definitions, 1-1
Dimensions, 3-4

F

Fault elimination, 6-1
Free space, 4-1

G

Gases, aggressive, 4-1
Glossary, 8-8

I

Installation, 4-1
 Electrical, 4-4
 Mechanical, 4-1

L

Legal regulations, 1-4
Liability, 1-4
List of special terms, see
 Glossary

M

Material, 7-1

O

Operating conditions, 3-2
Operator, 2-1

P

Personnel, qualified, 2-1

R

Rated data, 3-3
Recycling, 7-1

S

Safety information
 General, 2-2
 Layout, 2-3
Scope of delivery, 1-2
Supplement, 8-1

T

Technical data, 3-1
 Dimensions, 3-4
 Features, 3-1
 General data/operating conditions, 3-2
 Rated data, 3-3, 3-4
Troubleshooting, 6-1

W

Warranty, 1-4
Waste disposal, 7-1