

## Operating Instructions

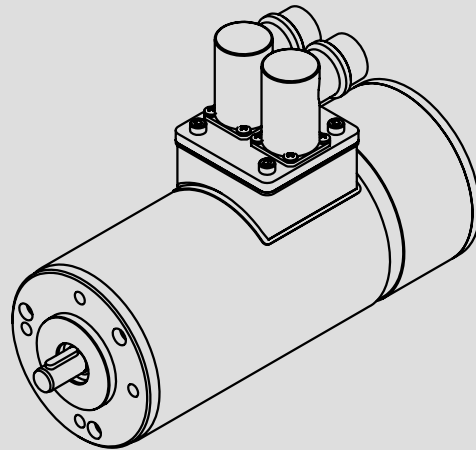

**SDSGA**

**Inverter-optimised asynchronous motors**



Please read these instructions before you start working!

Follow the enclosed safety instructions.

## Document history

Material No.	Version			Description
409413	1.0	03/1999	TD09	First edition for pilot series
409413	1.1	04/2001	TD09	Chapter 3.2: Extension of application conditions All chapters: Revised
452930	1.2	04/2002	TD09	Extended by chapter 5.2.1, type and quantity of lubricant
13209536	2.0	04/2007	TD09	Complete revision extended by gearbox type SPL 120
13209536	2.1	05/2009	TD09	Change of address

## Nameplates

### product series SDS□□

Field	Contents		Example																																
1	Manufacturer	CE identification	<table border="1"> <tr> <td colspan="2"><b>Lenze</b></td> <td>D-32696 Extertal</td> <td>CE</td> </tr> <tr> <td colspan="2"></td> <td>Germany</td> <td></td> </tr> <tr> <td>~Mot</td> <td colspan="2">Typ</td> <td></td> </tr> <tr> <td colspan="3">Nr.</td> <td></td> </tr> <tr> <td>W</td> <td></td> <td>1/min</td> <td></td> </tr> <tr> <td>V</td> <td></td> <td>Hz</td> <td></td> </tr> <tr> <td>A</td> <td>C</td> <td>μF</td> <td>IP</td> </tr> <tr> <td>S</td> <td>%ED</td> <td colspan="2">I.Cl.</td> </tr> </table>	<b>Lenze</b>		D-32696 Extertal	CE			Germany		~Mot	Typ			Nr.				W		1/min		V		Hz		A	C	μF	IP	S	%ED	I.Cl.	
<b>Lenze</b>		D-32696 Extertal		CE																															
		Germany																																	
~Mot	Typ																																		
Nr.																																			
W		1/min																																	
V		Hz																																	
A	C	μF	IP																																
S	%ED	I.Cl.																																	
2	Type of current	Motor type																																	
3	Date of manufacture	Commission No.																																	
4	Rated power (W)	Rated speed (1/min)																																	
5	Rated voltage (V)	Rated frequency (Hz)																																	
6	Rated current (A)	Rated torque (μF) Type of protection (IP)																																	
7	Operating mode	Thermal class Material No.																																	

### Gearboxes

Field	Contents		Example																				
1	Manufacturer	CE identification	<table border="1"> <tr> <td colspan="2"><b>Lenze</b></td> <td>D - 32696 Extertal</td> <td>CE</td> </tr> <tr> <td colspan="2"></td> <td>Germany</td> <td></td> </tr> <tr> <td colspan="3">Typ</td> <td></td> </tr> <tr> <td colspan="2">Nr.</td> <td>i</td> <td></td> </tr> <tr> <td>N<sub>2</sub>max</td> <td>Nm</td> <td></td> <td></td> </tr> </table>	<b>Lenze</b>		D - 32696 Extertal	CE			Germany		Typ				Nr.		i		N <sub>2</sub> max	Nm		
<b>Lenze</b>		D - 32696 Extertal		CE																			
		Germany																					
Typ																							
Nr.		i																					
N <sub>2</sub> max	Nm																						
2	Gearbox type																						
3	Commission No.	Ratio																					
4	Torque M <sub>2</sub> in Nm																						
5																							

### Brakes

#### Reference to installed brake

Field	Contents		Example				
1	Brake type/size	Voltage	<table border="1"> <tr> <td colspan="2">BFK457-05 205V DC</td> </tr> <tr> <td>13W 2Nm</td> <td>ID.475684</td> </tr> </table>	BFK457-05 205V DC		13W 2Nm	ID.475684
BFK457-05 205V DC							
13W 2Nm	ID.475684						
2	Electric power	Torque ID No.					

## Type code

### Inverter-optimised three-phase AC motors

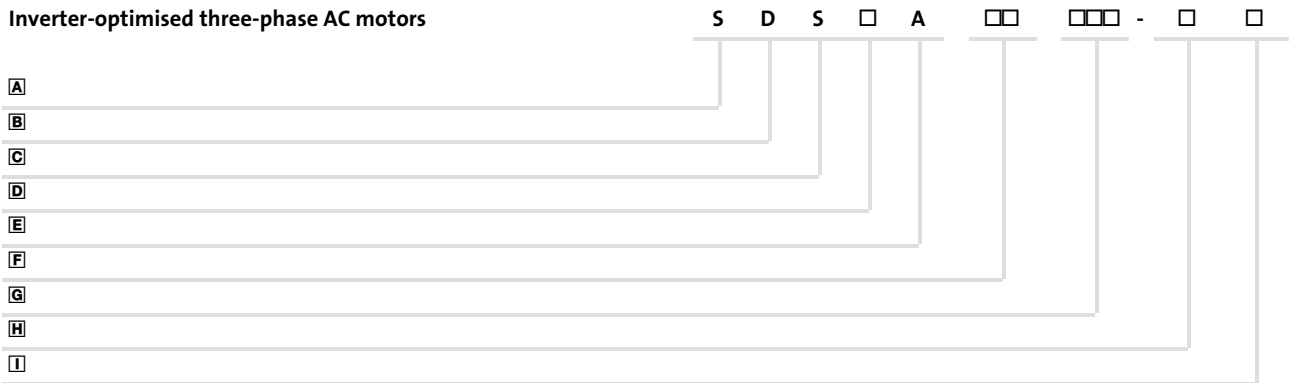

### Legend for SD□G□ type code

<b>A</b>	Product group	S	Small drives
<b>B</b>	Current type	D	Three-phase AC
<b>C</b>	Ventilation	S	Self ventilation (cooling by convection and radiation)
<b>D</b>	Design/housing	G	Smooth housing and round
		R	Ribbed housing, round
<b>E</b>	Machine type	A	Asynchronous machine
<b>F</b>	Built-on accessories	AG	Absolute value encoder
		BA	Brake and sin/cos absolute value encoder or SSI absolute value encoder
		BG	Brake, resolver and incremental encoder
		BI	Brake and incremental encoder (pulse encoder)
		BR	Brake
		BS	Brake and resolver
		BW	Brake, resolver and absolute value encoder
		B	Brake, encoder prepared
		G	No brake, encoder prepared
		XX	No brake, no encoder
		IG	Incremental encoder (pulse encoder)
		RS	Resolver
<b>G</b>	Frame size		
<b>H</b>	Overall length		
<b>I</b>	Number of pole pairs		

<b>1</b>	<b>Preface and general information</b> .....	<b>6</b>
1.1	About these Operating Instructions .....	6
1.1.1	Terminology used .....	6
1.1.2	Scope of supply .....	6
1.2	Legal regulations .....	7
<b>2</b>	<b>Safety instructions</b> .....	<b>8</b>
2.1	Personnel responsible for safety .....	8
2.2	Residual hazards .....	9
2.3	Safety instructions for low-voltage machinery .....	9
2.4	Definition of notes used .....	12
<b>3</b>	<b>Technical data</b> .....	<b>13</b>
3.1	Rated data .....	13
3.1.1	Shaft loads .....	14
3.2	General data and operating conditions .....	15
3.2.1	Other application conditions .....	16
<b>4</b>	<b>Mechanical installation</b> .....	<b>18</b>
4.1	Transport, storage and installation .....	18
4.2	Site .....	19
<b>5</b>	<b>Electrical installation</b> .....	<b>20</b>
5.1	Attachments .....	21
5.2	Gearbox mounting .....	21
5.2.1	Table of lubricants .....	22
5.2.2	Connection plan for SDSGALL inverter motor .....	24
<b>6</b>	<b>Commissioning</b> .....	<b>26</b>
6.1	Before switching on .....	26
6.2	During operation .....	27
<b>7</b>	<b>Maintenance/repair</b> .....	<b>28</b>
7.1	Temperature monitoring .....	28
7.2	Repair .....	29
<b>8</b>	<b>Troubleshooting and fault elimination</b> .....	<b>30</b>

# 1 Preface and general information

About these Operating Instructions  
Terminology used

## 1 Preface and general information

### 1.1 About these Operating Instructions

- ▶ These Operating Instructions inform about safety-relevant working on and with inverter-optimised motors of type SDS. They contain safety instructions which must be observed to enable trouble-free operation.
- ▶ All persons working on and with the inverter-optimised motors of type SDS must have the Operating Instructions available and observe the information and notes relevant for them.
- ▶ The Operating Instructions must always be complete and perfectly readable.

#### 1.1.1 Terminology used

Term	In the following text used for
Motor	Inverter-optimised motor of type SDS
Drive system	Drive system with inverter-optimised motor of type SDS or other Lenze drive components

#### 1.1.2 Scope of supply

- ▶ Short description

After receipt of the delivery, check immediately whether the items delivered match the accompanying papers. Lenze does not accept any liability for deficiencies claimed subsequently.

Claim

- ▶ visible transport damage immediately to the forwarder.
- ▶ visible deficiencies/incompleteness immediately to your Lenze representative.

## 1.2 Legal regulations

<b>Labelling</b>	<b>Nameplate</b>	<b>Manufacturer</b>	
	Lenze products are clearly labelled and defined by the indications on the nameplates.	Lenze GmbH & Co KG Kleinantriebe Postfach 10 13 52 D-31763 Hameln	
<b>Application as directed</b>	<p><b>Drive products</b></p> <ul style="list-style-type: none"> <li>● must only be operated under the conditions prescribed in these Instructions.</li> <li>● must only be used for the ordered and acknowledged application conditions.</li> <li>● meet the protection requirements of the EC "Low-Voltage Directive".</li> <li>● are not machines in the sense of the EC Machine Directive.</li> <li>● must not be used at powers higher or lower than indicated in these Instructions.</li> </ul> <p><b>Drive systems with SDS motors</b></p> <ul style="list-style-type: none"> <li>● meet the EC Directive "Electromagnetic compatibility" if they are installed according to the specifications of the CE-typical drive system.</li> <li>● are applicable: <ul style="list-style-type: none"> <li>– on public and non-public mains,</li> <li>– in industrial as well as residential and commercial premises.</li> </ul> </li> <li>● The end user is responsible for adhering to the EC directives in the machine application.</li> </ul> <p><b>Any other use shall be deemed inappropriate!</b></p>		
<b>Liability</b>	<ul style="list-style-type: none"> <li>● The information, data, and notes in these instructions were up to date at the time of printing. Claims referring to motors which have already been supplied cannot be derived from the information, illustrations and descriptions.</li> <li>● The process-related notes and circuit sections used in these instructions are suggestions whose suitability for the respective application must be checked. Lenze assumes no guarantee for the suitability of the listed procedures and circuit samples.</li> <li>● These operating instructions describe the product features without guaranteeing them.</li> <li>● No liability shall be accepted for damage and downtimes resulting from: <ul style="list-style-type: none"> <li>– non-observance of the operating instructions</li> <li>– unauthorised changes or modifications to the motors</li> <li>– operating errors</li> <li>– improper work on and with the motors.</li> </ul> </li> </ul>		
<b>Warranty</b>	<ul style="list-style-type: none"> <li>● Terms of warranty: see terms of sales and delivery of Lenze GmbH &amp; Co KG Kleinantriebe.</li> <li>● Warranty claims must be made to Lenze immediately after detecting the deficiency or fault.</li> <li>● The warranty is void in all cases in which liability claims cannot be made.</li> </ul>		
<b>Disposal</b>	<b>Material</b>	<b>Recycle</b>	<b>Dispose</b>
	Metal	●	-
	Plastic	●	-
	Assembled PCBs	-	●
<b>In-house transport</b>	<ul style="list-style-type: none"> <li>● Transport the motors free of vibration.</li> <li>● Avoid heavy shocks.</li> <li>● If possible, use manufacturer's packaging for transport. Cushioned bag ensures: <ul style="list-style-type: none"> <li>– dust protection</li> <li>– moisture protection</li> <li>– mechanical protection</li> </ul> </li> </ul>		
<b>Storage conditions</b>	<ul style="list-style-type: none"> <li>● Storage: <ul style="list-style-type: none"> <li>– free of vibration if a certain risk of vibration exists, we recommend to rotate the rotor once per week</li> <li>– dry, in a non-aggressive environment</li> <li>– free of dust</li> <li>– free of extreme temperature changes</li> </ul> </li> <li>● Corrosion: <ul style="list-style-type: none"> <li>– Steel parts are corrosion-protected when being delivered. Do not remove the protection! Check it every three months and, if necessary, renew it.</li> </ul> </li> </ul>		

## 2 Safety instructions

Personnel responsible for safety

## 2 Safety instructions

### 2.1 Personnel responsible for safety

#### Operator

- ▶ An operator is any natural or legal person who uses the drive system or on behalf of whom the drive system is used.
- ▶ The operator or his safety officer must ensure
  - that all relevant regulations, instructions and legislation are observed.
  - that only qualified personnel work with and on the drive system.
  - that the personnel have the Operating Instructions available for all corresponding operations.
  - that non-qualified personnel are prohibited from working with and on the drive system.

#### Skilled personnel

Skilled personnel are persons who - because of their education, experience, instructions, and knowledge about corresponding standards and regulations, rules for the prevention of accidents, and operating conditions - are authorised by the person responsible for the safety of the plant to perform the required actions and who are able to recognise potential hazards.

(See IEC 364, definition of skilled personnel)



## 2.2 Residual hazards

<p><b>Protection of persons</b></p>	<p>The motor surfaces can become very hot. Danger of burns when touching!</p> <ul style="list-style-type: none"> <li>● Install a guard, if necessary.</li> </ul> <p>High-frequency voltages can be capacitively transferred to the motor housing through the inverter supply.</p> <ul style="list-style-type: none"> <li>● Carefully earth the motor housing.</li> </ul> <p>Danger of unintentional starting or electrical shocks</p> <ul style="list-style-type: none"> <li>● Perform connection work only in the de-energised state, only with motor in standstill.</li> <li>● Built-in brakes are not fail-safe brakes.</li> </ul>
<p><b>Device protection</b></p>	<p>Built-in thermal detectors are <b>not a full protection</b> for the machine.</p> <ul style="list-style-type: none"> <li>● If necessary, limit the maximum current, perform a function block interconnection with disconnection after a few seconds of operation with <math>I &gt; I_N</math>, particularly if a danger of blocking exists.</li> <li>● The integrated overload protection does not prevent overload under all conditions!</li> </ul> <p>Built-in brakes are <b>not fail-safe brakes</b>.</p> <ul style="list-style-type: none"> <li>● Speed reduction is possible.</li> </ul> <p>Fuses are not a motor protection.</p> <ul style="list-style-type: none"> <li>● Use current-dependent motor protection switches for average operating frequency</li> <li>● Use built-in thermal detectors at high operating frequency.</li> </ul> <p>Excessive torques lead to a break of the motor shaft or demagnetisation</p> <ul style="list-style-type: none"> <li>● Do not exceed the maximum torques according to the catalogue.</li> </ul> <p>Lateral forces from the motor shaft are possible.</p> <ul style="list-style-type: none"> <li>● Perfectly align shafts of motor and driving machine to each other.</li> <li>● Speeds <math>&gt;3000 \text{ min}^{-1}</math> destroy the motor.</li> </ul>
<p><b>Fire protection</b></p>	<p>Fire hazard</p> <ul style="list-style-type: none"> <li>● Prevent contact with combustible substances.</li> </ul>

## 2.3 Safety instructions for low-voltage machinery

### in conformity with the Low-Voltage Directive 73/23/EEC

#### 1. General

Low-voltage machines have dangerous, live and rotating parts as well as possibly hot surfaces. All operations serving transport, connection, commissioning and maintenance are to be carried out by skilled, responsible technical personnel (observe prEN 50110-1/VDE 0105; IEC 364). Improper handling can cause severe injuries or material damage.

#### 2. Application as directed

These low-voltage machines are intended for industrial and commercial installations. They comply with the harmonised standards of the series EN 60034 (VDE 0530). Their use in hazardous areas is prohibited unless they are expressly intended for such use (follow additional instructions).

The enclosures  $\leq$  IP 23 are by no means intended for outdoor use. Air cooled designs are rated for ambient temperatures between  $-20^\circ\text{C}$  and  $+40^\circ\text{C}$  and altitudes of  $\leq 1000 \text{ m amsl}$ . Check indications on the nameplate and, if other observe them. The conditions on site must correspond to all nameplate data.

Low-voltage machines are components for installation in machinery as defined in the Machinery Directive 89/392/EEC. Commissioning is prohibited until conformity of the end product with this Directive has been established (observe i.a. EN 60204-1).

**3. Transport, storage**

The forwarder must be informed directly after receipt of the goods about all damage or deficiencies; if necessary, commissioning must be stopped. Tighten screwed-in ring bolts before transport. They are designed for the weight of the low-voltage machine, do not apply extra loads. If necessary, use suitable and adequately dimensioned means of transport (e.g. rope guides).

Remove the shipping brace before commissioning. Reuse it for further transports. For storage of low-voltage machines ensure a dry, dust-free and low-vibration ( $v_{rms} \leq 0.2 \text{ mm/s}$ ) environment (damage while being stored). Measure the insulation resistance before commissioning. If the values are  $\leq 1 \text{ k}$  per volt of rated voltage, dry the winding.

**4. Installation**

Ensure an even surface, solid foot or flange mounting and exact alignment if a direct clutch is connected. Avoid resonances with a rotational frequency and double mains frequency which may be caused during installation. Turn rotor by hand, listen for unusual slipping noises. Check the direction of rotation when the clutch is not active (observe section 5).

Use appropriate tools to mount or remove belt pulleys and clutches (heat generation!) and cover them with a touch guard. Avoid excessive belt tensions (technical list).

If required, provide pipe connections. Mounting positions with shaft end at top must be protected with a cover which avoids the ingress of foreign particles into the fan. Free circulation of the cooling air must be ensured. The exhaust air - also of other machines next to the drive system - must not be intaken again immediately.

**5. Electrical connection**

All operations must only be carried out by qualified and skilled personnel when the low-voltage machine is at standstill and when the machine is de-energised and protected against unintentional restart. This also applies to auxiliary circuits (e.g. anti-condensation heating).

Check safe isolation from the supply!

Exceeding of the tolerances specified in EN 60034-1 (VDE 0530, part 1) - voltage  $\pm 5\%$ , frequency  $\pm 2\%$ , wave form, symmetry - leads to excessive temperatures and affects the electromagnetic compatibility. Observe the indications on the nameplate and the diagram in the terminal box.

The connection must ensure a continuous and safe electrical supply (no loose wire ends); use appropriate cable terminals. The connection to the PE conductor must be safe.

The clearance between shining, live parts and earth must not fall below: 8mm at  $V_r \leq 550\text{V}$ , 10mm at  $V_r \leq 725\text{V}$ , 14mm at  $V_r \leq 1000\text{V}$ .

No foreign objects, dirt or moisture in the terminal box. All unused cable entries and the box itself must be sealed against dust and water. For the trial run without output elements, lock the key. Check brake operation before commissioning of low-voltage machines with brakes.

## **6. Operation**

Vibration severities  $v_{rms} \leq 3.5$  mm/s ( $Pr \leq 15$  kW) or 4.5mm/s ( $Pr > 15$  kW) are acceptable in coupled mode operation. In case of deviations from normal operation, e.g. increased temperatures, noises, vibration, find the cause and, if necessary, contact the manufacturer. Do not switch off the protection devices, not even for trial runs. Switch off the machine in problematic situations.

If the drive is exposed to dirt, clean it regularly.

Regrease the bearings using the relubrication facility while the low-voltage machine is running. Observe the saponification number. If the grease drain hole is sealed with a plug, (IP54 drive end; IP23 drive and non-drive end), remove the plug before commissioning. Seal the bore holes with grease. Replace the prelubricated bearings (ZZ-bearings) after approx. 10,000 h (2pole) or 20,000 h (multi-pole), but no later than after three to four years or according to the manufacturer's instructions.

#### 7. Inverter-driven operation for asynchronous motors

The indications in the terminal box inform about the limit values for the voltage that may be permanently applied to the insulation system of the motor. Example: SDSGA series.

**Permissible voltage:**

$$\hat{u} \leq 1.5 \text{ kV}$$

$$dv / dt \leq 5 \text{ kV} / \mu\text{s}$$

#### 2.4

#### Definition of notes used

The following pictographs and signal words are used in this documentation to indicate dangers and important information:

#### Safety instructions

Structure of safety instructions:



#### Danger!

(characterises the type and severity of danger)

#### Note

(describes the danger and gives information about how to prevent dangerous situations)

Pictograph and signal word	Meaning
<b>Danger!</b>	<b>Danger of personal injury through dangerous electrical voltage.</b> Reference to an imminent danger that may result in death or serious personal injury if the corresponding measures are not taken.
<b>Danger!</b>	<b>Danger of personal injury through a general source of danger.</b> Reference to an imminent danger that may result in death or serious personal injury if the corresponding measures are not taken.
<b>Stop!</b>	<b>Danger of property damage.</b> Reference to a possible danger that may result in property damage if the corresponding measures are not taken.

#### Application notes

Pictograph and signal word	Meaning
<b>Note!</b>	Important note to ensure troublefree operation
<b>Tip!</b>	Useful tip for simple handling
<b>Reference to another documentation</b>	Reference to another documentation

### 3 Technical data

#### 3.1 Rated data

- ▶ The most important rated data of the motor are indicated on the nameplate.
  - Further technical data can be obtained from the catalogs.
- ▶ The torques and weights indicated in Tab. 2 are guide values for the selection of the transmission elements and base.
- ▶ The rated data indicated on the nameplate refer to operation with Lenze servo inverters of the 9300 series with an inverter input voltage (mains voltage) of 400 V and an inverter frequency of 8 kHz.



**Note!**

- ▶ The motors can also be connected to inverters others than inverters of the 9300 series:
  - Observe the minimum frequencies (Tab. 1).
  - Depending on the modulation and control performance of the inverter it might be necessary to derate the power if excessive temperatures are detected (see chap. 3.2.1).

Motor type	Min. cycle frequency [kHz]
SD□□A 047...063	8

Tab. 1 Minimum permissible inverter cycle frequencies

## 3.1.1 Shaft loads

The permissible loads listed in the table (Tab. 2) are either radial forces or axial forces.

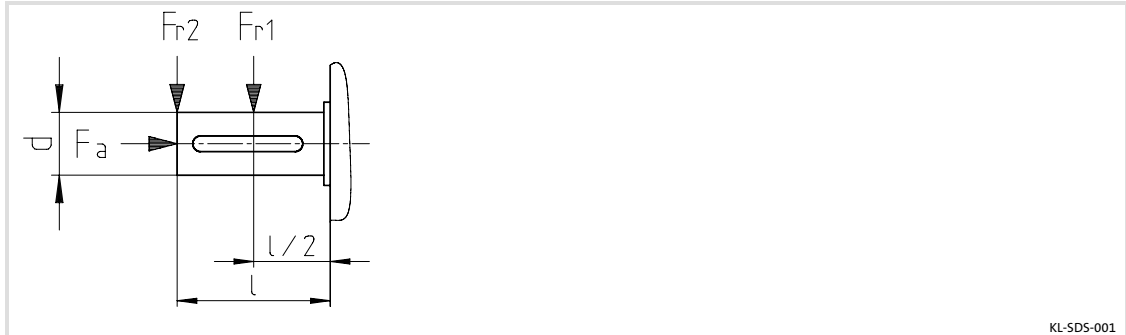

Fig. 1 Points of action of radial and axial loads

$F_a$  Permissible axial load

$F_{r1}$  Permissible radial load, acts on the **middle** of the shaft

$F_{r2}$  Permissible radial load, acts on the **end** of the shaft

Ref. to the nominal bearing service life of 10,000 h

Motor type	$P_r$ shaft	$n_r$ 1/min	$n$ 1/min	$M_r$ Nm	$M$ Nm	$J$ kg cm <sup>2</sup>	$U$ V	$I_r$ A	$F_{r1}/F_{r2}$ N	$F_a$ N	$\lambda$ $\cos\varphi$	$f$ HZ	$m_{motor}$ approx. kg	
SDSGARS□□	047-22	75	6000	2700	0.27	1.0	230/400	0.90/0.52	350/300	250	0.5	100	3.0	
	056-22	240		2790	0.81	3.2		1.404	1.49/0.86	560/530	430		0.714	4.0
	063-22	400		2800	1.35	5.0		2.796	2.12/1.23	650/605	510		0.7	5.3
	063-32	600		2825	1.9	8.0		4.21	3.00/1.74					6.8

Tab. 2 Rated data for standard design

Formula designations			
$P_r$	Rated power	$F_{r1}/F_{r2}$	Permissible radial load
$M_r$	Rated torque	$F_a$	Permissible axial load
$I_r$	Rated current	$n_r$	Rated speed
$U$	Rated voltage	$m_{motor}$	Motor weight (mass)
$f$	Rated frequency	$N$	max. speed
$J$	Moment of inertia	$M$	max. torque
$\lambda$	Power factor		

3.2 General data and operating conditions

Field	Values		
Conformity	CE	Low-Voltage Directive (73/23/EEC)	
Climatic conditions	Average relative humidity 85 %, without condensation		
Permissible temperature range	Non-ventilated or with integral fan without brake or with spring-operated brake	-20 °C ... +40 °C	Without power derating, above +40 °C with power derating see catalog
Protection type	See nameplate		Protection types only apply for horizontal installation
Thermal class	F (155 °C) to DIN-IEC 34 / VDE 0530		The insulation will be weakened or destroyed when the limit temperature is exceeded
Tropical insulation	Not guaranteed		
Permissible voltage	1.5 kV peak value		5 kV/μs rate of rise
Vibration	Up to 2.0g / 20m/s <sup>2</sup> without resonance excitation, e.g. of the fan.		
Mounting positions	Can be used in all mounting positions		Vertical arrangements to DIN-IEC 34 part 7 are possible if they meet the designs Motors with directly mounted gearbox must not be mounted in mounting position with motor at the bottom
Permissible installation height h	h ≤ 1000 m amsl 1000 m amsl < h ≤ 4000 m amsl		Without power derating With power derating, see catalog

## 3.2.1 Other application conditions

- ▶ Other application conditions require a power derating or torque reduction using the factors listed in table 2 and 3 (see below).

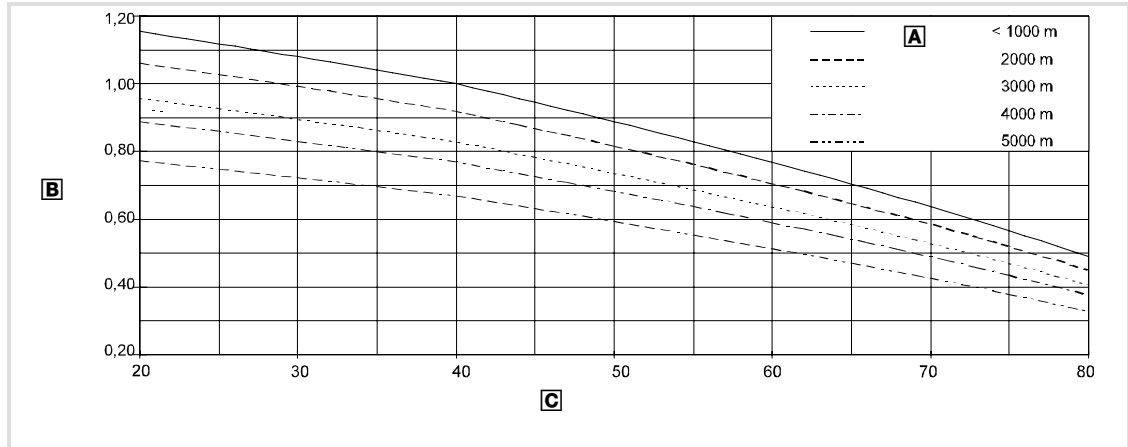

- Ⓐ Installation height
- Ⓑ Permissible continuous torque  $M_{perm}/M_{cont}$  40 °C 1000 m
- Ⓒ Cooling air / ambient temperature [°C]

**Stop!**

- ▶ The motor will be destroyed when the maximum motor speed is exceeded
- ▶ Do not exceed the maximum torques specified in Tab. 2!
  - Torques as high as indicated can be reached through appropriate motor-controller combinations.
  - Excessive torques might result in a break of the motor shaft!

**Note!**

- ▶ Excessive axial and radial forces reduce the bearing service life.
  - Observe the permissible forces to Tab. 2!
  - Calculation basis:  
Bearing service life  $L_{h10} = 10000$  h  
Torque  $M = 2.5 M_r$

The permissible continuous power is calculated as follows:

$$P' = k_v \cdot k_h \cdot P_c$$

with  $P_c$  being the permissible continuous power under normal conditions. A corresponding relation applies to the torque:

$$M' = k_v \cdot k_h \cdot M_c$$

with  $M_c$  being the permissible continuous torque under normal conditions.



**3.2.1.1 Power derating**

Power derating for other application conditions					
Cooling air temperature °C <sup>1)</sup>	40	45	50	55	60
Power derating $k_v$ <sup>1)</sup>	1.00	0.95	0.90	0.83	0.77
Installation height amsl in m <sup>2)</sup>	1000	2000	3000	4000	5000
Power derating $k_h$ <sup>2)</sup>	1.00	0.92	0.83	0.77	0.67

- 1) Derating for other ambient and cooling air temperatures
- 2) Derating for other installation heights

## 4 Mechanical installation

Transport, storage and installation

## 4 Mechanical installation

### 4.1 Transport, storage and installation



#### **Danger!**

- ▶ Use appropriate means of transport or hoists:
  - Ensure safe fixing.
- ▶ Transport the motors free of vibrations.
- ▶ Avoid heavy shocks.

#### **Storage**

- ▶ free of vibration
  - if a certain risk of vibration exists, we recommend to rotate the rotor once per week
- ▶ dry, in a non-aggressive environment
- ▶ free of dust
- ▶ free of extreme temperature changes

#### **Corrosion**

- ▶ Steel parts are corrosion-protected when being delivered. Do not remove the protection! Check it every three months and, if necessary, renew it.

#### **Installation**

The motors are tested for operation and are ready for use.

#### **Preparations**

- ▶ Remove the corrosion protection from the steel parts.
- ▶ Check for transport damage and fix key, if necessary.
- ▶ The mounting depends on the motor design, the weight and the motor torque.
- ▶ Before mounting the motor, foot and flange surfaces must contact the mounting surfaces evenly. Insufficient motor alignment reduces the service life of the bearings and the transmission elements!
- ▶ Clutches and other transmission elements must be mounted according to the corresponding instructions. Avoid shocks onto the shafts and do not exceed the permissible radial and axial forces to avoid damage to the bearings!
- ▶ Provide sufficient space for unimpeded ventilation.

4.2

Site



**Danger!**

Do not use in hazardous areas!

**The motors are designed for the following rated conditions:**

- ▶ Ambient and cooling air temperatures up to +40 °C (in case of other temperatures see chapter 3.2.1).
- ▶ Installation height up to 1000 m amsl (in case of other installation heights see chapter 3.2.1).
- ▶ Ensure unimpeded ventilation!
- ▶ The exhaust air must not be intaken again!
- ▶ Operation within the permissible control range for self-ventilated motors.

## 5 Electrical installation



### Danger!

- ▶ Electrical connection must only be carried out by qualified personnel!
- ▶ Connections must only be made when the equipment is de-energised!  
Danger through unintended starts or electric shocks.



### Stop!

It must be ensured that the supply voltage corresponds to the voltage indicated on the nameplate.

### Voltage supply

- ▶ Inverter-optimised motors
  - must be supplied by inverters.
  - connect the encoders mounted to the motor with the corresponding connections of the inverter.
- ▶ Holding brake (as option)
- ▶ Follow the Operating Instructions for the inverter used to connect it.

### Cable cross-sections

- ▶ Select appropriate connection cables to avoid impermissible heating (DIN 57100/VDE 0100 T523).
- ▶ When extremely long cables are used, we recommend to use the next cable cross section up to reduce the power losses. Observe the minimum cross sections to DIN VDE 0298-4.
- ▶ Establish the electrical connection as shown in the circuit diagram attached to each motor. The circuit diagrams for the standard designs can be found in chapter 5.2.2.

### Motor protection

- ▶ The motor cable cannot be protected by temperature monitorings or PTC thermistors in the motor winding:
  - Take measures to DIN 57100 / VDE 0530.
- ▶ The inverter changes current and voltage such that the output current can be considerably higher than the input current. The motor cable cannot be protected via the mains input fuses of the inverter:
  - Take measures to DIN 57100 / VDE 0530.
- ▶ Ensure careful earthing of the motor housing!
  - If the motor is inverter driven, high-frequency voltages may be capacitively transferred to the motor housing.

## 5.1 Attachments



### **Danger!**

Ensure that the drives are disconnected from the power supply when working on them!



### **Stop!**

- ▶ Unload motors or secure load applied to the drive.
- ▶ Do not use hammers or other heavy tools for assembly or disassembly!

Motors with B-side attachments (brakes and/or encoders) are assembled, electrically connected and tested for operation. Observe the corresponding Operating Instructions!

## 5.2 Gearbox mounting



### **Stop!**

- ▶ Do not exceed the permissible radial and axial forces to avoid damage to the bearings!
- ▶ All shaft seals must be generally equipped with a mounting sleeve to avoid damage to the seal lips.

## Worm gearbox type SSN

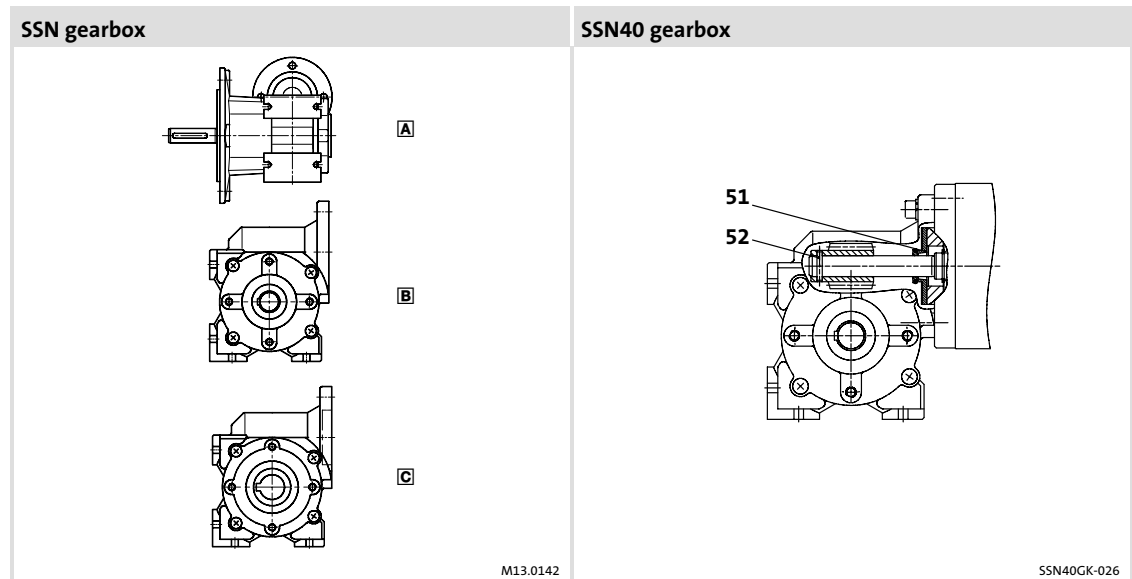

Fig. 2 Worm gearbox

- A** Solid shaft design with flange
- B** Solid shaft design without flange
- C** Hollow shaft design

**Stop!**

After the shaft seal (51) has been mounted, mount the worm. Ensure stability of the motor shaft end when pinning (50).

Use the screws and washers in the assembly kit for the motor to mount the gearbox to the motor:

## 5.2.1

## Table of lubricants

Gearbox type	Type of lubricant	Quantity [ml]
SSN31-1FVAL	CLP PG460	60
SSN31-1FVAR		40
SSN31-1FDAR		40
SSN31-1FHAR		40
SSN40-1FVAL		120
SSN40-1FVAR		80
SSN40-1FDAR		80
SSN40-1FHAR		80

Planetary gearbox type SPL

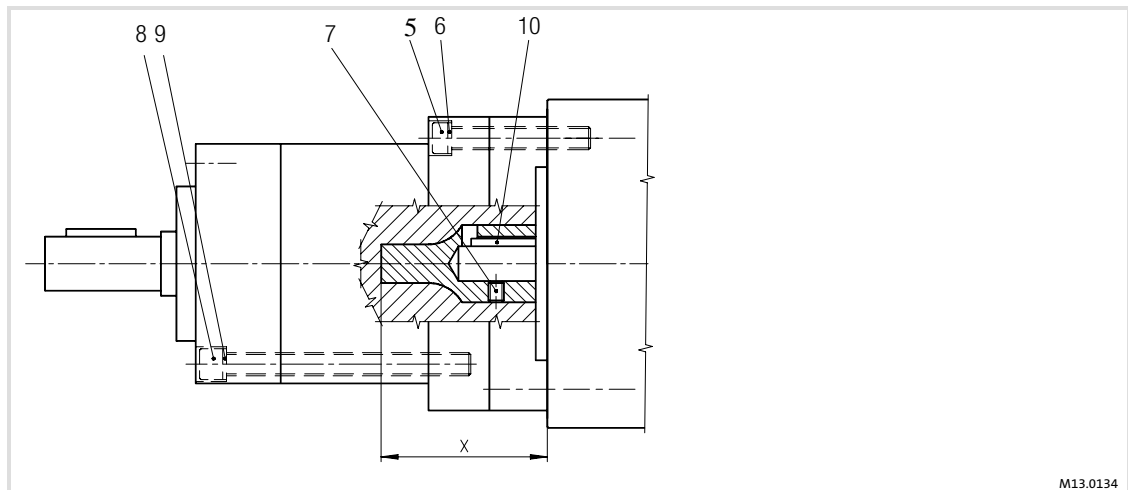

Fig. 3

- |   |                        |    |                                |
|---|------------------------|----|--------------------------------|
| 5 | Screw                  | 8  | Screw                          |
| 6 | Washer                 | 9  | Washer                         |
| 7 | Setscrew               | 10 | Key (not applicable for SPL42) |
| 7 | Spring pin (for SPL42) |    |                                |

Gearbox type / size	Dimensions	
	Flange size	Dimension x in mm
SPL42	---	31
SPL52	C80	38.6
SPL62	C80 / C90	43 / 43
SPL81	C90 / C105	51.6 / 58.6
SPL120	C105	73.7

- When using a planetary gearbox, the force is transmitted from the gearbox to the motor by means of a key (does not apply to type SPL 42!).



**Stop!**

For IP55 use a fluid sealant between mounting flange and gearbox (e.g. Loctite).

## 5 Electrical installation

Gearbox mounting  
Connection plan for SDSGALL inverter motor

### 5.2.2 Connection plan for SDSGA□□ inverter motor

#### Parameter settings for 9300 servo inverters



#### Note!

More detailed information on wiring according to EMC guidelines can be obtained from the Operating Instructions for Lenze 9300 servo inverters.

Code	Meaning	Setting							
		SDSGA□□047-22		SDSGA□□056-22		SDSGA□□063-22		SDSGA□□063-32	
		Y	Δ	Y	Δ	Y	Δ	Y	Δ
C0006	Servo asynchronous (Y)	2	22	2	22	2	22	2	22
C0025	Resolver	RsX							
C0081	Pr (kW)	0.075		0.24		0.40		0.60	
C0084	Rphase (Ohm)	72		20.9		10		8.5	
C0085	Xleak (mH)	267		103		50		26	
C0086	COMMON	0							
C0087	nr (1/min)	2700		2790		2800		2825	
C0088	Ir (A)	0.52	0.90	0.86	1.50	1.23	2.12	1.74	3
C0089	fr (Hz)	100							
C0090	Ur (V)	390	230	390	230	390	230	390	230
C0091	cos phi	0.50		0.70					

#### ... for motor and brake

Inverter motor	Pin No.	Connection name	Connection to:	Pin assignment
SDSGA□□047-22 SDSGA□□056-22 SDSGA□□063-22 SDSGA□□063-32	1	Y1	Brake	
	2	Y2		
	PE	PE	Circuit breaker	
	4	U	Motor phase	
	5	V		
	6	W		

#### ... for resolver and thermal contact

Inverter motor	Pin No.	Connection name	Connection to:	Pin assignment
SDSGA□□047-22 SDSGA□□056-22 SDSGA□□063-22 SDSGA□□063-32	1	+ Ref	Resolver	
	2	- Ref		
	3		Resolver	
	4	+ Cos		
	5	- Cos		
	6	+ Sin		
	7	- Sin		
	8			
	9			
	10			
	11	+	KTY/thermal switch	
	12	-		

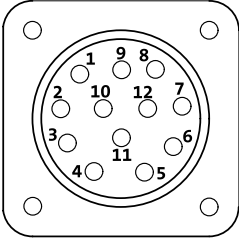

... for absolute value encoder/incremental encoder and thermal contact

Inverter motor	Pin No.	Connection name	Connection to:	Pin assignment
SDSGA□□047-22 SDSGA□□056-22 SDSGA□□063-22 SDSGA□□063-32	1	B	Track B / + SIN	
	2	$\bar{A}$	Track A inverted / - COS	
	3	A	Track A	
	4	+ 5 V	Supply + 5V + 8V	
	5	GND	Ground	
	6	$\bar{Z}$	Zero track inverted / - RS485	
	7	Z	Zero track / + RS485	
	8		Not assigned	
	9	$\bar{B}$	Track B inverted / - SIN	
	10		Not assigned	
	11	+ KTY	Temperature sensor +	
	12	-KTY	Temperature sensor -	

### 6 Commissioning



#### Stop!

- ▶ Ensure that the drives are disconnected from the power supply when working on them!
- ▶ The drive must only be commissioned by qualified personnel!
- ▶ Do not use the drive in rooms exposed to explosion danger!
- ▶ Danger of fire! Do not use flammable detergents or solvents to clean the drive.
- ▶ Avoid overheating! Deposits and dirt on the drives impede the necessary heat dissipation and must be removed frequently.

Ensure that no foreign particles ingress into the motor!

#### 6.1 Before switching on

- ▶ Before commissioning
- ▶ Before commissioning after a longer standstill
- ▶ Before commissioning after repair and maintenance of the motor



#### Stop!

Commission the drive system according to the Operating Instructions for the controller.

#### Check:

- ▶ Are the mechanical and electrical mountings and fixings o.k.?
- ▶ Are the electrical connections o.k.?
- ▶ Is the cooling air circulation o.k.?
- ▶ Is the protection against overheating (temperature monitoring evaluation) o.k.?
- ▶ Is the motor connected correctly?
- ▶ Does the parameter setting correspond to the motor (see Operating Instructions for the controller)?

## 6.2 During operation



### Stop!

- ▶ Danger of fire! Do not use flammable detergents or solvents to clean the motor.
- ▶ Avoid overheating! Deposits and dirt on the drives impede the necessary heat dissipation and must be removed frequently.



### Danger!

The motor surfaces must not be touched during operation. The surface temperature of the motors can be up to 95°C depending on the operating status. If necessary, provide protection against contact to protect yourself from burns. Observe cooling times!

- ▶ Depending on the application conditions, the drive must be checked frequently during operation.

#### Please observe particularly:

- unusual noises or temperatures,
  - loose fixing elements,
  - the condition of the electrical cables,
  - oil drops or leakages,
  - extreme vibrations, or similar,
  - changes in speed
  - impeded heat dissipation or deposits on the drive system and in the air ducts.
- ▶ In the event of faults, please see the table in chapter 8. If the fault cannot be eliminated, please contact the Lenze Service.

7 **Maintenance/repair**



**Danger!**

- ▶ Ensure that no voltage is applied to the drive system while working on it!
- ▶ High temperatures of the motor surfaces. Observe cooling times!
- ▶ Unload motor or secure loads which are applied to the drive!
- ▶ Ensure that no foreign particles ingress into the motor!

7.1 **Temperature monitoring**

If the surface temperatures are higher than usual, it might be necessary to check the actual winding temperature:

- ▶ Detect the winding temperature by means of a 4-conductor resistance measurement at the motor power connections.
- ▶ The resistance should be measured immediately after switch-off and standstill of the motor.

**Procedure**

1. Remove the plug-in connector X10. For terminal box designs, interrupt the power supply between inverter and motor.
2. Measure the resistance between the following contacts or terminals:
  - Plug-in connector X10:  
Contacts 4↔5, 5↔6 and 6↔4
  - Terminal box X11:  
Terminals 1↔2, 2↔3 and 3↔1
3. The mean value calculated from three measuring values equals the double phase resistance (star connection).
  - Enter the mean value as "R<sub>2</sub>" in the following formula and calculate the winding temperature "ϑ<sub>2</sub>" ("R<sub>1</sub>" from Tab. 3):

$$\vartheta_2 [^{\circ}\text{C}] = \frac{R_2 \times 255}{R_1} - 235$$

Motor type	Winding resistance	
	Δ 230V	Y 390V
SDSG□□□047	28.7	86
SDSG□□□056	13.1	39.6
SDSG□□□063-22	6.7	20
SDSG□□□063-32	3.8	11.4

Tab. 3 Winding resistances of servo motors (between two terminals)

**7.2 Repair**

- ▶ It is recommended to have all repairs performed by Lenze Service.
- ▶ Delivery of spare parts is available upon request.

### 8 Troubleshooting and fault elimination

- ▶ If faults occur during operation, take the following steps:
  - Check the possible causes of the faults by means of the following table.
  - Please observe the corresponding chapters in the Operating Instructions for the other components of the drive system.
- ▶ If the fault cannot be eliminated by one of the measures listed in these Operating Instructions, please contact the Lenze Service.

Fault	Cause	Remedy
Motor does not start	Voltage supply interrupted	<ul style="list-style-type: none"> <li>● Check error message at drive controller</li> <li>● Check electrical connection (chapter 5)</li> </ul>
	Controller inhibited	<ul style="list-style-type: none"> <li>● Check display at drive controller</li> <li>● Check controller enable</li> </ul>
	Resolver cable is interrupted	<ul style="list-style-type: none"> <li>● Check error message at drive controller</li> <li>● Check resolver cable</li> </ul>
	Brake does not release	Check electrical connection Check air gap (see Brake operating instructions) Check continuity of magnetic coil
	Drive is blocked	Check components for easy movement, remove foreign bodies if necessary
Motor stops suddenly and does not start again	Temperature monitoring is activated	<ul style="list-style-type: none"> <li>● Let motor cool down                             <ul style="list-style-type: none"> <li>– Reduce the load by prolonging the acceleration times</li> </ul> </li> </ul>
	Overload monitoring of the inverter is activated	<ul style="list-style-type: none"> <li>● Check controller settings</li> <li>● Reduce the load by prolonging the acceleration times</li> </ul>
Wrong direction of rotation of the motor, correct display at controller	Reversed motor cable and resolver cable	Exchange 2 phases of the motor cable <b>and</b> the +COS/-COS connections of the resolver
Motor rotates slowly in a direction which cannot be influenced via the controller	Polarity reversal of motor or resolver cable	Exchange 2 phases of the motor cable <b>or</b> the +COS/-COS connections of the resolver
Motor does not rotate, gearbox output is not running	Defective wheel-hub connection	Check the connection, replace the key, if necessary, repair by the manufacturer
	Toothing worn out	Repair by the manufacturer
Uneven running	Insufficient shielding of motor or resolver cable	Check shielding and grounding (chapter 5)
	Drive controller gain too large	Adjust the gains of the controllers (see Drive controller operating instructions)
Vibrations	Insufficiently balanced coupling elements or machine	Rebalance
	Poor alignment of the drive train	Realign the machine set, if necessary, check the base
	Loose fixing screws	Check and tighten screw connections
Running noises	Foreign bodies inside the motor	Repair by manufacturer, if necessary
	Bearing damage	Repair by manufacturer, if necessary
Surface temperature > 140 °C	Overload of drive	<ul style="list-style-type: none"> <li>● Check load and, if necessary, reduce load by prolonging the acceleration times</li> <li>● Check the winding temperature (chapter 7.1)</li> </ul>
	Heat removal restricted due to deposit build-up	Clean surface and cooling ribs of the drives





© 05/2009



Lenze GmbH & Co KG Kleinantriebe  
Postfach 10 13 52  
D-31763 Hameln  
Germany



+49 (0)51 54 / 82-0



+49 (0)51 54 / 82-28 00



Lenze@Lenze.de



www.Lenze.com

Service

Lenze Service GmbH  
Breslauer Straße 3  
D-32699 Extertal  
Germany



00 80 00 / 24 4 68 77 (24 h helpline)



+49 (0)51 54 / 82-13 96



Service@Lenze.de

BA 13.0008 - EN ■ 13209536 ■ 2.1 ■ TD09

10 9 8 7 6 5 4 3 2 1