

SIEMENS

SIMOTICS DC

DC motor

Type 1GG6

Operating Instructions / Installation Instructions

Edition

02/2016

Answers for industry.

SIEMENS

SIMOTICS DC

DC motor 1GG6

Operating Instructions
Installation Instructions

<u>Introduction</u>	1
<u>Safety notes</u>	2
<u>Description</u>	3
<u>Preparations for use</u>	4
<u>Assembling</u>	5
<u>Electrical connection</u>	6
<u>Commissioning</u>	7
<u>Operation</u>	8
<u>Maintenance</u>	9
<u>Spare Parts</u>	10
<u>Disposal</u>	11
<u>Service and Support</u>	A
<u>Technical data and drawings</u>	B
<u>Quality documents</u>	C
<u>Checklists</u>	D

Legal information

Warning notice system

This manual contains notices you have to observe in order to ensure your personal safety, as well as to prevent damage to property. The notices referring to your personal safety are highlighted in the manual by a safety alert symbol, notices referring only to property damage have no safety alert symbol. These notices shown below are graded according to the degree of danger.

 DANGER
indicates that death or severe personal injury will result if proper precautions are not taken.

 WARNING
indicates that death or severe personal injury may result if proper precautions are not taken.

 CAUTION
indicates that minor personal injury can result if proper precautions are not taken.

NOTICE
indicates that property damage can result if proper precautions are not taken.

If more than one degree of danger is present, the warning notice representing the highest degree of danger will be used. A notice warning of injury to persons with a safety alert symbol may also include a warning relating to property damage.

Qualified Personnel

The product/system described in this documentation may be operated only by **personnel qualified** for the specific task in accordance with the relevant documentation, in particular its warning notices and safety instructions. Qualified personnel are those who, based on their training and experience, are capable of identifying risks and avoiding potential hazards when working with these products/systems.

Proper use of Siemens products

Note the following:

 WARNING
Siemens products may only be used for the applications described in the catalog and in the relevant technical documentation. If products and components from other manufacturers are used, these must be recommended or approved by Siemens. Proper transport, storage, installation, assembly, commissioning, operation and maintenance are required to ensure that the products operate safely and without any problems. The permissible ambient conditions must be complied with. The information in the relevant documentation must be observed.

Trademarks

All names identified by ® are registered trademarks of Siemens AG. The remaining trademarks in this publication may be trademarks whose use by third parties for their own purposes could violate the rights of the owner.

Disclaimer of Liability

We have reviewed the contents of this publication to ensure consistency with the hardware and software described. Since variance cannot be precluded entirely, we cannot guarantee full consistency. However, the information in this publication is reviewed regularly and any necessary corrections are included in subsequent editions.

Table of contents

1	Introduction.....	13
1.1	About these instructions.....	13
2	Safety notes.....	15
2.1	Information for the nominated person in control of the electrical installation.....	15
2.2	The five safety rules.....	15
2.3	Qualified personnel.....	16
2.4	Safe handling.....	16
2.5	Electrostatic sensitive devices.....	18
2.6	Electromagnetic compatibility.....	19
2.7	Interference immunity.....	19
2.8	Influence on the line power supply through a strongly irregular torque.....	19
2.9	Electromagnetic fields when operating electrical power engineering installations.....	20
3	Description.....	21
4	Preparations for use.....	25
4.1	Safety-related aspects to consider when configuring the plant.....	25
4.2	Observing the operating mode.....	25
4.3	Noise emissions.....	25
4.4	Ensuring cooling.....	26
4.5	Interlock circuit for the external fan motor.....	26
4.6	System-inherent frequencies.....	26
4.7	Torsional loading of the drive train due to faults in the electrical supply.....	27
4.8	Transport and storage.....	27
4.8.1	Transport markings.....	27
4.8.2	Checking the delivery.....	27
4.8.3	Attaching the rotor shipping brace prior to storage.....	28
4.8.4	Checking the load handling attachments.....	28
4.8.5	Requirements for safe lifting and transporting.....	29
4.8.6	Transporting the machine set.....	30
4.8.7	Lifting and transporting the machine.....	30
4.8.8	Storage.....	32
4.8.9	Protection against corrosion.....	34
5	Assembling.....	35
5.1	Preparations for installation.....	35
5.1.1	Requirements for installation.....	35
5.1.2	Insulation resistance and polarization index.....	36

5.1.3	Testing the insulation resistance and polarization index.....	36
5.1.4	Preparing the mating faces.....	39
5.2	Lift the machine to where it will be installed, and position it.....	39
5.2.1	Preconditions for correct alignment and secure attachment	39
5.2.2	Checking the load handling attachments.....	40
5.2.3	Removing the rotor shipping brace.....	40
5.2.4	Removing anti-corrosion protection.....	41
5.2.5	Mounting the output elements.....	42
5.2.6	Lifting and transporting the machine.....	43
5.2.7	Putting the machine down.....	45
5.2.8	Drain condensate.....	45
5.2.9	Roughly aligning the machine.....	45
5.3	Installing the machine.....	46
5.3.1	Safety instructions for installation.....	46
5.3.2	Selecting fixing screws.....	47
5.3.3	Preconditions for smooth, vibration-free operation.....	47
5.3.4	Aligning the machine to the driven machine and attaching it to it (foundation mounting)	47
5.3.5	Aligning the machine to the driven machine and attaching it to it (flange mounting, vertical).....	49
5.3.6	Aligning the machine to the driven machine and mounting (flange, horizontal IM B5).....	49
5.3.7	Mounting the machine.....	50
5.3.8	Axial and radial forces.....	50
5.4	Ensuring cooling by means of external fans.....	51
6	Electrical connection.....	53
6.1	Selecting cables.....	53
6.2	Bringing in and routing the cables.....	53
6.3	Terminal designations.....	54
6.4	Connecting cables.....	54
6.5	Connecting the main circuit.....	55
6.6	Connecting the grounding conductor.....	57
6.7	Internal equipotential bonding.....	58
6.8	Connecting the auxiliary circuits.....	58
6.9	Connecting an external fan motor.....	60
6.10	Connecting temperature monitoring for the stator winding.....	60
6.11	Completing connection work.....	61
7	Commissioning.....	63
7.1	Preparing for commissioning.....	63
7.2	Measure the insulation resistance before commissioning.....	64
7.3	Greasing the roller bearings prior to commissioning.....	64
7.4	Minimum radial forces for cylindrical roller bearings.....	65
7.5	Commissioning an external fan.....	66

7.6	Switch on.....	67
7.7	Overspeed.....	68
7.8	Switch off.....	69
8	Operation.....	71
8.1	Switching on the machine.....	72
8.2	Regreasing roller bearings.....	73
8.3	Deactivating.....	73
8.4	Switching on again after an emergency switching-off.....	73
8.5	Stoppages.....	73
8.5.1	Measures in non-operational periods.....	74
8.5.2	Avoidance of damage to roller bearings during stoppages.....	75
8.5.3	Measurement of the insulation resistance after an extended stoppage.....	75
8.6	Decommissioning the machine.....	76
8.7	Re-commissioning the machine.....	76
8.8	Special operating conditions.....	76
8.9	Faults	77
8.9.1	Inspections in the event of faults.....	77
8.9.2	Faults in operation.....	78
8.9.3	Faults at the external fan.....	78
8.9.4	Roller bearing faults.....	79
8.9.5	Brush faults.....	80
8.9.6	Commutator faults.....	81
9	Maintenance.....	83
9.1	Inspection and maintenance.....	83
9.1.1	Initial inspection.....	84
9.1.2	MTTR.....	86
9.1.3	Main inspection.....	86
9.1.4	Regreasing rolling-contact bearings.....	87
9.1.5	Regreasing intervals and grease types.....	88
9.1.6	Clean the machine.....	89
9.1.7	Checking the carbon brushes.....	89
9.1.8	Replacing the carbon brushes.....	90
9.1.9	Setting the brush rocker and brush holder.....	91
9.1.10	Maintaining the commutator.....	91
9.1.11	Maintaining terminal boxes.....	93
9.1.12	Touch up any damaged paintwork.....	94
9.2	Repair.....	94
9.2.1	Prepare servicing work.....	95
9.2.2	Disassembling the machine.....	96
9.2.3	Removing rolling-contact bearings.....	97
9.2.4	Installing the machine.....	97
9.2.5	Mounting the rolling-contact bearings.....	98
9.2.6	Replacing the speed encoder.....	99
9.2.6.1	Speed sensor with conical hub.....	99

9.2.6.2	Speed sensor for overhung mounting.....	100
9.2.6.3	Speed sensor for construction type IM B5.....	102
10	Spare Parts.....	105
10.1	Ordering data.....	105
10.2	Ordering spare parts via the Internet.....	106
10.3	Using commercially available spare parts.....	106
10.4	Stator and rotor, shaft height 160.....	107
10.5	Stator and rotor, shaft heights 180 to 280.....	109
10.6	External fan.....	111
10.7	Rolling-contact bearing.....	112
10.7.1	Rolling-contact bearing for 1G.6, 1H.6, shaft height 160 without regreasing device, drive end.....	112
10.7.2	Rolling-contact bearing for 1G.6, 1H.6, shaft height 160 without regreasing device, non-drive end.....	113
10.7.3	Rolling-contact bearing for 1G.6, 1H.6, shaft height 160 with regreasing device, drive end....	114
10.7.4	Rolling-contact bearing for 1G.6, 1H.6, shaft height 160 with regreasing device, non-drive end.....	115
10.7.5	Rolling-contact bearing for 1G.6, 1H.6, shaft heights 180 to 200 without regreasing device, drive end.....	116
10.7.6	Rolling-contact bearing for 1G.6, 1H.6, shaft heights 180 to 200 without regreasing device, non-drive end.....	117
10.7.7	Rolling-contact bearing for 1G.6, 1H.6, shaft heights 180 to 200 with regreasing device, drive end.....	118
10.7.8	Rolling-contact bearing for 1G.6, 1H.6, shaft heights 180 to 200 with regreasing device, non-drive end.....	119
10.7.9	Rolling-contact bearing for 1G.6, 1H.6, shaft heights 225 to 280 with regreasing device, drive end.....	120
10.7.10	Rolling-contact bearing for 1G.6, 1H.6, shaft heights 225 to 280 with regreasing device, non-drive end.....	121
10.7.11	Rolling-contact bearing seal 1G.6, 1H.6, 1G.7, 1H.7.....	122
10.8	Terminal boxes.....	123
10.8.1	Main terminal box gk 602 / gk 702.....	123
10.8.2	1XB7700 terminal box.....	125
10.8.3	1XB7710 main terminal box.....	126
10.8.4	1XB7942 main terminal box.....	127
10.8.5	Auxiliary terminal box.....	128
10.9	Speed sensor.....	129
10.9.1	Shaft height 160.....	129
10.9.1.1	Speed sensor with conical hub.....	129
10.9.1.2	Speed sensor for overhung mounting.....	130
10.9.1.3	Speed sensor for construction type IM B5.....	131
10.9.2	Shaft heights 180 to 630.....	132
10.9.2.1	Speed sensor with conical hub.....	132
10.9.2.2	Speed sensor for overhung mounting.....	133
10.9.2.3	Speed sensor for construction type IM B5.....	134

11	Disposal.....	135
11.1	Introduction.....	135
11.2	RoHS - restricting the use of certain hazardous substances.....	135
11.3	Country-specific legislation.....	135
11.4	Dismantling the machine.....	135
11.5	Disposal of components.....	136
A	Service and Support.....	137
B	Technical data and drawings.....	139
B.1	Tightening torques for screw and bolt connections.....	139
C	Quality documents.....	141
D	Checklists.....	143
D.1	Switching on.....	144
D.2	Commissioning.....	145
D.3	Inspection at standstill.....	146
D.4	Inspection when the motor is running.....	147
	Index.....	149

Tables

Table 3-1	Insulation classes.....	22
Table 3-2	Machine design	22
Table 3-3	Data on the rating plate.....	23
Table 4-1	Tightening torques for the shaft screw on the rotor shipping brace.....	31
Table 5-1	Stator winding insulation resistance at 40° C.....	37
Table 5-2	Permissible deviations for aligning the machine with flexible coupling.....	48
Table 6-1	Terminal designations in example B1.....	54
Table 6-2	Terminal box connection data.....	55
Table 6-3	Tightening torque of screws with cable lugs.....	57
Table 6-4	Tightening torque of screws with ground terminals.....	58
Table 7-1	Minimum radial forces.....	66
Table 8-1	Vibration magnitude as a function of vibration frequency.....	73
Table 8-2	Faults in operation.....	78
Table 8-3	Cooling system faults	78
Table 8-4	Roller bearing faults	79
Table 8-5	Brush faults.....	80
Table 8-6	Commutator faults.....	81
Table 9-1	MTTR in fault-free operation	86

Table 9-2	Suitable greases for rolling-contact bearings (down to -20 °C).....	88
Table 9-3	Commutator overhaul – minimum permissible diameter.....	92
Table 9-4	Recommended torques for tightening the shaft journal.....	99
Table 9-5	Recommended torques for tightening the shaft journal.....	101
Table 9-6	Recommended torques for tightening the coupling.....	102
Table 9-7	Tightening torques for mounting couplings.....	103
Table 10-1	Spare parts stator and rotor 1G.6, shaft height 160.....	108
Table 10-2	Spare parts stator and rotor 1G.6, 1H.6, shaft heights 180 to 200.....	110
Table 10-3	Spare parts external fan 1GG6.....	111
Table 10-4	Spare parts rolling-contact bearing for 1G.6, 1H.6, shaft height 160 without regreasing device.....	112
Table 10-5	Spare parts rolling-contact bearing for 1G.6, 1H.6, shaft height 160 without regreasing device.....	113
Table 10-6	Spare parts rolling-contact bearing for 1G.6, 1H.6, shaft height 160 with regreasing device....	114
Table 10-7	Spare parts rolling-contact bearing for 1G.6, 1H.6, shaft height 160 with regreasing device....	115
Table 10-8	Spare parts rolling-contact bearing for 1G.6, 1H.6, shaft heights 180 to 200 without regreasing device.....	116
Table 10-9	Spare parts rolling-contact bearing for 1G.6, 1H.6, shaft heights 180 to 200 without regreasing device.....	117
Table 10-10	Spare parts rolling-contact bearing for 1G.6, 1H.6, shaft heights 180 to 200 with regreasing device.....	118
Table 10-11	Spare parts rolling-contact bearing for 1G.6, 1H.6, shaft heights 180 to 200 with regreasing device.....	119
Table 10-12	Spare parts rolling-contact bearing for 1G.6, 1H.6, shaft heights 225 to 280 with regreasing device.....	120
Table 10-13	Spare parts rolling-contact bearing for 1G.6, 1H.6, shaft heights 225 to 280 with regreasing device.....	121
Table 10-14	Spare parts sealing for rolling-contact bearing for 1H.6, 1G.6.....	122
Table 10-15	Spare parts main terminal box gk 602 / 702.....	124
Table 10-16	Spare parts main terminal box 1XB7700.....	125
Table 10-17	Spare parts main terminal box 1XB7710.....	126
Table 10-18	Spare parts main terminal box 1XB7942.....	127
Table 10-19	Spare parts auxiliary terminal box.....	128
Table 10-20	Spare parts speed sensor with conical hub for shaft height 160.....	129
Table 10-21	Spare parts speed sensor for overhung mounting for shaft height 160.....	130
Table 10-22	Spare parts speed sensor for construction type IM B5 for shaft height 160.....	131
Table 10-23	Spare parts speed sensor with conical hub for shaft heights 180 to 630.....	132
Table 10-24	Spare parts speed sensor for overhung mounting for shaft heights 180 to 630.....	133
Table 10-25	Spare parts speed sensor for construction type IM B5 for shaft heights 180 to 630.....	134
Table B-1	Tightening torques for screw/bolt connections with a tolerance of $\pm 10\%$	139
Table D-1	Items to check during switch-on.....	144
Table D-2	Items to check during commissioning.....	145

Table D-3	Items to inspect when machine is at standstill.....	146
Table D-4	Items to inspect when the motor is running.....	147

Images

Image 3-1	Block diagram of motor type 1GG.....	21
Image 3-2	Schematic rating plate.....	23
Image 4-1	Rotor shipping brace without coupling (1) and with coupling (2).	30
Image 5-1	Balancing type on the drive-end side.....	42
Image 5-2	Schematic diagram: Aligning the machine to the driven machine.....	48
Image 6-1	Connection of main terminals with cable lug.....	56
Image 6-2	Connection of auxiliary terminals with cable lug.....	56
Image 6-3	Connection without cable lugs.....	56
Image 7-1	External fan with cover sheet ①.....	67
Image 9-1	Adjusting the brush rocker: fixed part (1), brush rocker (2).....	91
Image 9-2	Reworking the slots.....	93
Image 9-3	Final work on the commutator after skimming.....	93
Image 9-4	Speed sensor assembly	100
Image 9-5	Speed sensor assembly	101
Image 9-6	Speed encoder mounting.....	103
Image 10-1	Side view 1G.6 shaft height 160.....	107
Image 10-2	Front view 1G.6 with shaft height 160.....	107
Image 10-3	Detail X brush holder 1G.6 shaft height 160.....	108
Image 10-4	Side view 1G.6, 1H.6 shaft heights 180 to 200.....	109
Image 10-5	Front view 1G.6, 1H.6 shaft heights 180 to 200.....	109
Image 10-6	Detail X brush holder 1G.6, 1H.6 shaft heights 180 to 200.....	110
Image 10-7	External fan 1GG6.....	111
Image 10-8	Sealing for rolling-contact bearing for 1H.6, 1G.6.....	122
Image 10-9	Main terminal box gk 602 / 702.....	123
Image 10-10	1XB7700 main terminal box.....	125
Image 10-11	Main terminal box 1XB7710	126
Image 10-12	Main terminal box 1XB7942	127
Image 10-13	Auxiliary terminal box.....	128
Image 10-14	Speed sensor with conical hub for shaft height 160.....	129
Image 10-15	Speed sensor for overhung mounting for shaft height 160.....	130
Image 10-16	Speed sensor for construction type IM B5 for shaft height 160.....	131
Image 10-17	Speed sensor with conical hub for shaft heights 180 to 630.....	132
Image 10-18	Speed sensor for overhung mounting for shaft heights 180 to 630.....	133
Image 10-19	Speed sensor for construction type IM B5 for shaft heights 180 to 630.....	134

Introduction

1.1 About these instructions

These instructions describe the machine and explain how to handle it, from initial delivery to final disposal of the equipment. Keep these instructions for later use.

Read these operating instructions before you handle the machine and follow the instructions to become familiar with its design and operating principles and thus ensure safe, problem-free machine operation and long service life.

Please contact the Service Center (Page 137) if you have any suggestions on how to improve this document.

Text format features

The warning notice system is explained on the rear of the inside front. Always follow the safety instructions and notices in these instructions.

In addition to the safety-related warning notices which you must read, you will find the text in these instructions is formatted in the following way:

1. Handling instructions are always formatted as a numbered list. Always perform the steps in the order given.
- Lists are formatted as bulleted lists.
 - Lists on the second level are hyphenated.

Note

A Note is an important item of information about the product, handling of the product or the relevant section of the document. Notes provide you with help or further suggestions/ideas.

Safety notes

2.1 Information for the nominated person in control of the electrical installation

This electric machine has been designed and built in accordance with the specifications contained in Directive 2006/95/EC up to April 19, 2016 - and from April 20, 2016 according to Directive 2014/35/EU ("Low-Voltage Directive") and is intended for use in industrial plants. Please observe the country-specific regulations when using the electric machine outside the European Community. Follow the local and industry-specific safety and setup regulations.

The persons responsible for the plant must ensure the following:

- Planning and configuration work and all work carried out on and with the machine is only to be done by qualified personnel.
- The operating instructions must always be available for all work.
- The technical data as well as the specifications relating to the permissible installation, connection, ambient and operating conditions are taken into account at all times.
- The specific setup and safety regulations as well as regulations on the use of personal protective equipment are observed.

Note

Use the services and support provided by the appropriate Service Center (Page 137) for planning, installation, commissioning, and servicing work.

You will find safety instructions in the individual sections of this document. Follow the safety instructions for your own safety, to protect other people and to avoid damage to property.

Observe the following safety instructions for all activities on and with the machine.

2.2 The five safety rules

For your own personal safety and to prevent material damage when carrying out any work, always observe the safety-relevant instructions and the following five safety rules according to EN 50110-1 "Working in a voltage-free state". Apply the five safety rules in the sequence stated before starting work.

Five safety rules

1. Disconnect the system.
Also disconnect the auxiliary circuits, for example, anti-condensation heating.
2. Secure against reconnection.
3. Verify absence of operating voltage.

2.4 Safe handling

- 4. Ground and short-circuit.
 - 5. Provide protection against adjacent live parts.
- To energize the system, apply the measures in reverse order.

2.3 Qualified personnel

All work at the machine must be carried out by qualified personnel only. For the purpose of this documentation, qualified personnel is taken to mean people who fulfill the following requirements:

- Through appropriate training and experience, they are able to recognize and avoid risks and potential dangers in their particular field of activity.
- They have been instructed to carry out work on the machine by the appropriate person responsible.

2.4 Safe handling

Workplace safety depends on the attentiveness, care, and common sense of the personnel who install, operate, and maintain the machine. In addition to the safety measures cited, as a matter of principle, the use of caution is necessary when you are near the machine. Always pay attention to your safety.

Also observe the following to prevent accidents:

- General safety regulations applicable in the country where the machine is deployed.
- Manufacturer-specific and application-specific regulations
- Special agreements made with the operator
- Separate safety instructions supplied with the machine
- Safety symbols and instructions on the machine and its packaging



 WARNING
Live parts Electric machines contain live parts. Fatal or severe injuries and substantial material damage can occur if the covers are removed or if the machine is not handled, operated, or maintained properly. <ul style="list-style-type: none">• Always observe the “five safety rules” (Page 15) when carrying out any work on the machine.• Only remove the covers using the methods described by these operating instructions.• Operate the machine properly.• Regularly and correctly maintain the machine.



! WARNING

Rotating parts

Electric machines contain dangerous rotating parts.

Fatal or severe injuries and substantial material damage can occur if the covers are removed or if the machine is not handled, operated, or maintained properly.

- Only remove the covers using the methods described by these operating instructions.
- Operate the machine properly.
- Regularly and correctly maintain the machine.
- Secure free-standing shaft ends and other rotating parts such as couplings, belt pulleys etc. against touch.



! WARNING

Hot surfaces

Electric machines have hot surfaces. Do not touch these surfaces. They could cause burns.

- Allow the machine to cool before starting work on the machine.
- Only remove the covers using the methods described by these operating instructions.
- Operate the machine properly.



! CAUTION

Hazardous substances

Chemical substances required for the setup, operation and maintenance of machines can present a health risk.

Poisoning, skin damage, cauterization of the respiratory tract, and other health damage may result.

- Read the information in these operating instructions and the product information supplied by the manufacturer.
- Observe the relevant safety regulations and wear the personal protective equipment specified.

! CAUTION

Flammable substances

Chemical substances required for the setup, operation and maintenance of machines may be flammable.

Burns and other damage to health and material may result.

- Read the information in these operating instructions and the product information supplied by the manufacturer.
- Observe the relevant safety regulations and wear the personal protective equipment specified.

 WARNING
Noise emissions During operation, the machine's noise emission levels can exceed those permitted at the workplace, which can cause hearing damage. Take steps to reduce noise, such as introducing covers and protective insulation or adopting hearing protection measures, so that the machine can be operated safely within your system.

2.5 Electrostatic sensitive devices

ESD protective measures



NOTICE
Electrostatic discharge Electronic modules contain components that can be destroyed by electrostatic discharge. These modules can be easily destroyed by improper handling. To protect equipment against damage, follow the instructions given below. <ul style="list-style-type: none">• Only touch electronic modules if you absolutely have to work on them.• The body of the person concerned must have been electrostatically discharged and grounded immediately before any electronic modules are touched.• Electronic modules should not be brought into contact with electrically insulating materials, such as:<ul style="list-style-type: none">– Plastic film– Plastic parts– Insulating table supports– Clothing made of synthetic fibers• Always place electrostatic sensitive devices on conductive bases.• Always pack, store and transport electronic modules or components in conductive packaging, such as:<ul style="list-style-type: none">– Metallized plastic or metal containers– Conductive foam material– Domestic aluminum foil

2.8 Influence on the line power supply through a strongly irregular torque

The necessary ESD protective measures for electrostatic sensitive devices are illustrated once again in the following drawings:

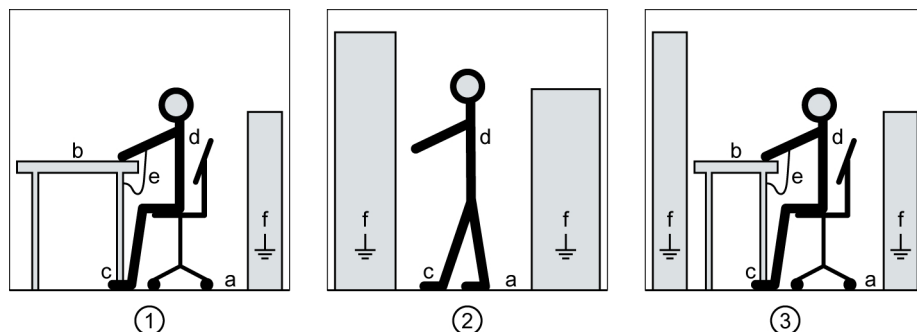

(1) Sitting

a = conductive floor surface

d = ESD overall

(2) Standing

b = ESD table

e = ESD wristband

(3) Standing/sitting

c = ESD shoes

f = cabinet ground connection

2.6 Electromagnetic compatibility

This machine is designed in accordance with IEC/EN 60034 and, when used as prescribed, it satisfies the requirements of European Directive 2004/108/EC - from April 20, 2016 of the European directive 2014/30/EU on Electromagnetic Compatibility.

2.7 Interference immunity

The machine fulfills the requirements regarding interference immunity in conformity with IEC/EN 61000-6-2.

On machines with integrated sensors (e.g. PTC thermistors), the manufacturer of the overall system must himself ensure sufficient interference immunity by selecting suitable sensor signal leads and evaluation units.

2.8 Influence on the line power supply through a strongly irregular torque

A strongly irregular torque, for example with the drive of a reciprocating motor, forces a non-sinusoidal motor current. The emerging harmonics can have an impermissible influence on the line power supply via the connection lines.

2.9 Electromagnetic fields when operating electrical power engineering installations



WARNING

Interference to electronic devices caused by electrical power equipment

Electrical power equipment generate electric fields during operation. Potentially lethal malfunctions can occur in medical implants, e.g. pacemakers, in the vicinity of electrical power equipment. Data may be lost on magnetic or electronic data carriers.

- It is forbidden for people with pacemakers to enter the vicinity of the machine.
- Protect the personnel working in the plant by taking appropriate measures, such as erecting identifying markings, safety barriers and warning signs and giving safety talks.
- Observe the nationally applicable health and safety regulations.
- Do not carry any magnetic or electronic data media.

Description

Applications

DC machine of the 1GG6... series are implemented with open-circuit or closed-circuit cooling with a laminated stator yoke.

They are designed for a wide range of drive and energy conversion applications and comply with the harmonized standards of series IEC / EN 60034 (VDE 0530).



WARNING

Risk of explosion

This machine is not designed for use in hazardous areas. An explosion can occur if the machine is operated in these areas. This can result in death, serious injury or material damage.

Never operate this machine in hazardous areas.

Schematic diagram

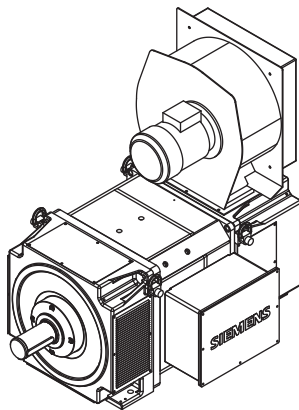

Image 3-1 Block diagram of motor type 1GG...

Cooling

The cooling system is designed as an open cooling circuit with cooling method IC06. The machine is cooled using ambient air. A separately-driven fan draws in and blows out the ambient air.

Design

The machine has no housing, but is designed with a fully laminated stator yoke which allows a rate of current change of up to $250 I_N/\text{sec}$.

Insulation system

The high-quality DURIGNIT® 2000 insulation system means that the motors are suitable for use in both tropical humidity and industrial environments. You will find the insulation classes in the following table.

Table 3-1 Insulation classes

Series	Insulation class
1GG5	155 (F)
1GH5	
1HS5	
1HQ5	
1GG6, 1GG7	180 (H)
1GH6, 1GH7	
1HS6, 1HS7	
1HQ6, 1HQ7	

Degree of protection

The machine has degree of protection IP23.

Ambient conditions

Unless otherwise specified, the rated powers apply for continuous operation at a coolant temperature of ≤ 40 °C and an installation altitude of up to 1000 m above sea level. Please note any data to the contrary on the rating plate. Operating conditions must comply with the specifications on the rating plate.

Machine design

You will find regulations and standards for rating and testing this motor on the rating plate. The machine design basically complies with the following standards. Please refer to the EC or EU Declaration of Conformity for the versions of the harmonized standards referenced.

Table 3-2 Machine design

Characteristic	Standard
Ratings and operating performance	IEC/EN 60034-1
Degree of protection	IEC/EN 60034-5
Cooling	IEC/EN 60034-6
Construction type	IEC/EN 60034-7
Terminal markings and direction of rotation	IEC/EN 60034-8
Noise emission	IEC/EN 60034-9
Vibration severity grades	IEC/EN 60034-14
Vibration limits	DIN ISO 10816-3

Rating plate

The rating plate shows the identification data and the most important technical data. The data on the rating plate and the contractual agreements define the limits of proper usage.

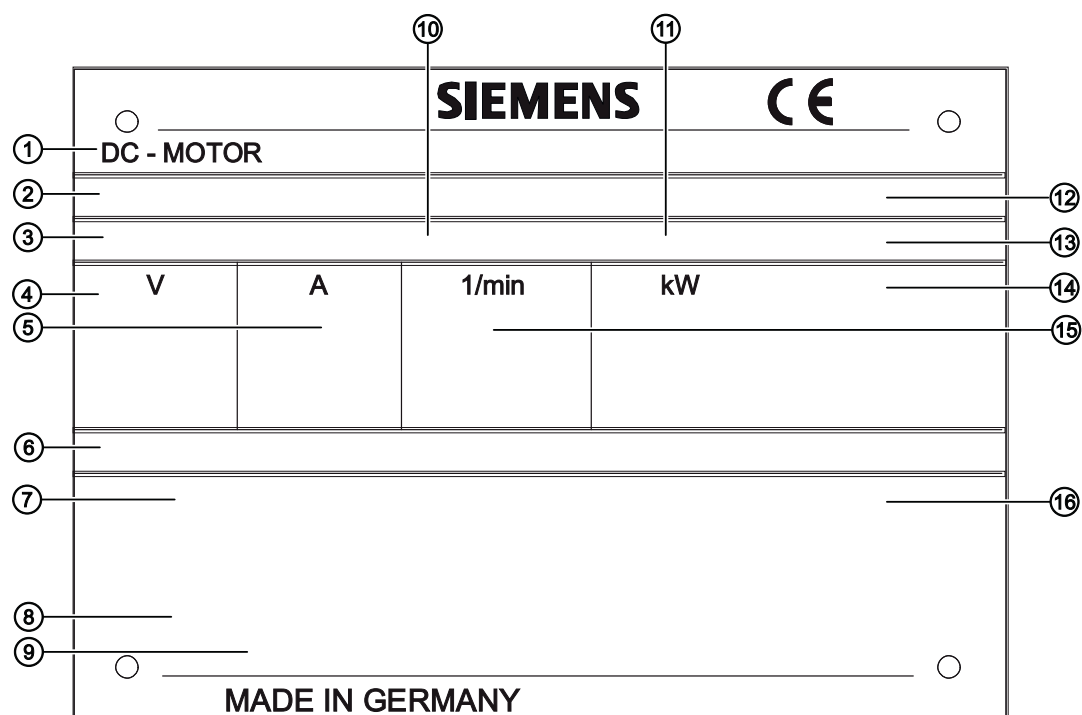

Image 3-2 Schematic rating plate

Table 3-3 Data on the rating plate

Item	Description	Item	Description
①	Type	⑨	Supply connection data
②	Serial number	⑩	Degree of protection
③	Temperature class	⑪	Construction type
④	Armature voltage [V]	⑫	Standards and regulations
⑤	Armature current [A]	⑬	Motor weight [t]
⑥	Exciter data	⑭	Power [kW]
⑦	Cooling method	⑮	Speed [RPM]
⑧	Brush equipment	⑯	Air flow direction

Terminal box

The terminal box contains terminals for the main circuit and auxiliary circuit (excitation) and for other auxiliary circuits. The terminal box fulfills degree of protection IP55.

The screw-mounted entry plate is not normally supplied with holes. This enables you to adapt the type, number, and size of the screw connections to the specific cabling requirements.

If a separate wiring space is prescribed for specific auxiliary circuits, an additional auxiliary terminal box is mounted on the side of the terminal box.

Rolling-contact bearing

The rolling-contact bearing is normally a floating bearing at the drive end and a locating bearing at the non-drive end. You will find further information in section "Spare parts (Page 105)."

On machines with a regreasing device, the lubricant plate specifies the types of rolling-contact bearing fitted.

Preparations for use

Good planning and preparation of machine applications are essential in terms of keeping installation simple and avoiding errors, ensuring safe operation, and allowing access to the machine for servicing and corrective maintenance.

This chapter outlines what you need to consider when configuring your plant in relation to this machine and the preparations you need to make before the machine is delivered.

4.1 Safety-related aspects to consider when configuring the plant

A number of residual risks are associated with the machine. These are described in the chapter titled "Safety information" (Page 15) and in related sections.

Take appropriate safety precautions (covers, barriers, markings, etc.) to ensure the machine is operated safely within your plant.

4.2 Observing the operating mode

Observe the machine's operating mode. Use a suitable control system to prevent overspeeds, thus protecting the machine from damage.

4.3 Noise emissions

 WARNING
Noise emissions
During operation, the machine's noise emission levels can exceed those permitted at the workplace, which can cause hearing damage.
Take steps to reduce noise, such as introducing covers and protective insulation or adopting hearing protection measures, so that the machine can be operated safely within your system.

4.4 Ensuring cooling

Ensure that the machine is sufficiently cooled by the cooling air flow at the installation site:

- Ensure that the cooling air can flow in and out unobstructed. The full air flow provided by the fan is only possible if air can freely enter the impeller. In the axial direction, ensure a clearance of at least 1 x air intake diameter.
- Make sure that the machine does not draw in the hot discharged air again.
- For machines with a vertical type construction with an air intake from above, ensure that the air inlets are protected against the ingress of foreign bodies and water.

4.5 Interlock circuit for the external fan motor

Interlock circuit for the external fan motor

For machines with external fans, install an interlock circuit that prevents the main machine being switched on if the external fan is not operational.

See also

Connecting an external fan motor (Page 60)

4.6 System-inherent frequencies

NOTICE
Machine damage caused by system resonances
The system consisting of the foundation and machine set must be configured and matched in such a way that no system resonances can arise and result in the permissible vibration levels being exceeded. Excessive vibrations can damage the machine set. The vibration limit values according to DIN ISO 10816-3 must not be exceeded.

4.7 Torsional loading of the drive train due to faults in the electrical supply

In the event of faults in the electrical supply, such as failure of the field supply or short circuit across terminals, excessive air gap torques can occur, which can lead to additional torsional loads on the drive train.

 WARNING
Serious damage to the machine
If the configuration does not correctly recognize the mechanical torsional loadings of the shaft assembly, this can lead to serious damage to the machine. This can result in death, serious injury or material damage.
When planning the system, make due allowance for the maximum air gap torques that can occur.

Note

The system planner is responsible for the entire drive train.

4.8 Transport and storage

4.8.1 Transport markings

The packing differs depending on the transport type and size. If not otherwise contractually agreed, the packaging corresponds to the packing guidelines for International Standards for Phytosanitary Measures (ISPM).

Comply with the images shown on the packaging. Their meaning is as follows:



This way up



Fragile goods



Keep dry



Keep cool



Center of gravity



Do not use hand hook



Attach here

4.8.2 Checking the delivery

The components are assembled on an individual basis. When you take receipt of the delivery, please check immediately whether the scope of the delivery matches up with the accompanying documents. No claims relating to defects/items missing from the delivery will be accepted if they are submitted at a later date.

- Report any apparent transport damage to the delivery agent immediately.
- Immediately report any apparent defects/missing components to your contact partner.

These Operating Instructions are part of the scope of delivery; keep them in a location where they can be easily accessed.

4.8.3 Attaching the rotor shipping brace prior to storage

NOTICE
Bearing damage caused by vibration
If storage conditions are inappropriate there is a risk of bearing seizure damage. This can result in material damage, such as damage to bearings caused by vibration.
<ul style="list-style-type: none">• On machines that have been supplied with a rotor shipping brace, secure the rotor as per the notes on transportation.• Protect the machine against strong radial vibrations, since the rotor shipping brace might not absorb these completely.

NOTICE
Bearing damage when being transported
If the customer has already mounted parts, for example coupling, belt pulley, etc., the bearing can be damaged during transport.
<ul style="list-style-type: none">• In this case, make sure that the customer uses a rotor shipping brace.

4.8.4 Checking the load handling attachments

Inspect the load handling attachments such as the load stands, lifting eyes and ring bolts and also the lifting gear, before lifting the machine:

- Inspect the load handling attachments on the machine for possible damage. Replace any load handling attachments that are found to be damaged.
- Check before use that the load handling attachments are correctly secured.
- When lifting the machine, use only approved and undamaged lifting gear of sufficient rated capacity. Check these before using them.

 WARNING
The machine can be dropped
If the load handling attachments and lifting gear are damaged or not correctly secured, the machine may be dropped during lifting. This can result in death, serious injury or material damage. Inspect the load handling attachments and lifting gear before use.

4.8.5 Requirements for safe lifting and transporting

To safely lift and transport the machine, the following requirements must be met:

- Personnel operating cranes and fork-lift trucks must be appropriately qualified.
- If the motor is packed, depending on the weight, size and on-site conditions, lift crates and transport frames using a fork-lift truck or a crane with slings.
 - Use a crane or fork-lift truck suitable for the load.
 - The center of gravity of the goods and the positions of the hoisting points are indicated on the packaging. Do not hoist any goods with damaged packaging.
- When lifting the machine, use only approved and undamaged sling guides and spreaders of sufficient rated capacity. Check the lifting equipment prior to its use. The weight of the machine is shown on the rating plate.
- When lifting the machine, refer to the information on the lifting plate.
 - Comply with the specified spreading angles.
 - Do not exceed the maximum lifting acceleration and lifting speed specified on the lifting plate. Lift the machine without jerking it.
Acceleration $a \leq 0.4 \text{ g}$ ($\approx 4 \text{ m/s}^2$)
Velocity $v \leq 20 \text{ m/min}$
- Use only the load carrying device on the stator frame for lifting.

 WARNING
The machine can tip over, slip or fall down during transport if a different construction is used
If you do not transport or lift the machine in a position appropriate for its construction, the machine can tip, slip into the lifting equipment or fall down. This can result in death, serious injury or material damage.
<ul style="list-style-type: none">• Use only the load carrying device on the stator frame for lifting.• Use the load carrying device appropriate for the machine position.• Use suitable rope guiding or spreading devices. The weight of the machine is shown on the rating plate.

 WARNING
The machine can fall over, shift or fall down during transport if the center of gravity is not symmetrical
If the center of gravity of a load is not located centrally between the attachment points, the motor can tip over or slip out of the lifting equipment and fall when it is being transported or lifted. This can result in death, serious injury or material damage.
<ul style="list-style-type: none">• Comply with the handling instructions on the machine when transporting it.• Be aware of the possibility of different loads on the sling ropes or lifting straps and the carrying capacity of the lifting equipment.• Always take account of the center of gravity when transporting or lifting the motor. If the center of gravity is not located centrally between the attachment points, then position the hoisting hook above the center of gravity.

4.8.6 Transporting the machine set

<p>⚠ WARNING</p> <p>Falling down of the machine</p> <p>The lifting lugs on the machine are designed only for the weight of the machine. If a machine set is lifted and transported on a single machine, this can lead to mechanical failure of the lifting lug. The machine or machine set may fall. This can result in death, serious injury or material damage.</p> <ul style="list-style-type: none">• Do not lift machine sets by attaching lifting tackle to the individual machines.• Use only the equipment provided, e.g. the openings or lugs on the base plates, for transporting machine sets. Note the maximum capacity of the lifting lug.
--

4.8.7 Lifting and transporting the machine

<p>NOTICE</p> <p>Transport damage if the rotor shipping brace is not used.</p> <p>The motor can be damaged if it is jolted during transport.</p> <p>This can result in material damage.</p> <ul style="list-style-type: none">• Always transport the motor with the rotor shipping brace supplied. The rotor shipping brace must be securely attached during transportation. Do not remove the rotor shipping brace until you are ready to push on the output element.• When the motor has to be transported after the output element is pushed on, take other appropriate measures to fix the axial position of the rotor, see the following figure.
--

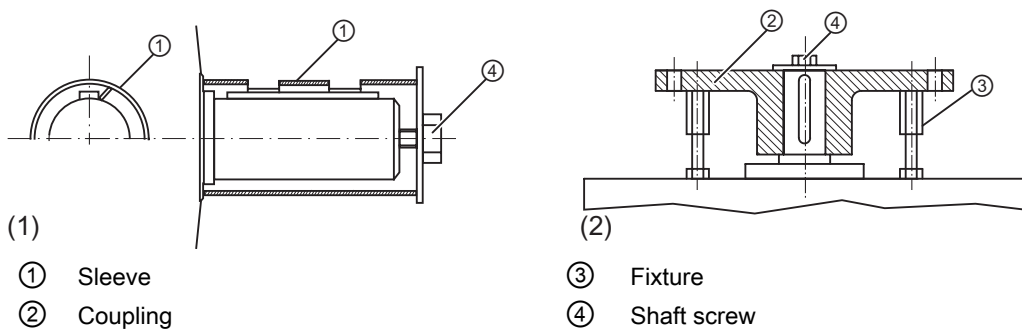

Image 4-1 Rotor shipping brace without coupling (1) and with coupling (2).

Table 4-1 Tightening torques for the shaft screw on the rotor shipping brace

Thread in the shaft extension	Tightening torque	Preload
M20	50 Nm	12 kN
M24	100 Nm	20 kN
M30	180 Nm	32 kN

 **WARNING**

Transporting or lifting the machine

The motor or the motor set may only be transported and lifted with the hoisting lugs, as it might otherwise tip over or slip out of the lifting equipment. Death, serious injury, or material damage can result.

- Always use the lugs on the stator frame to lift the motor. Use suitable rope guidance or spreading devices. You will find the weight of the motor on the rating plate.
- Only lift and transport the motors in a position appropriate to their design.
- Vertical-design motors must always be transported in the vertical position if the rotor is not fixed. If transport in a horizontal position should prove to be necessary in special cases, then fix the rotor before bringing the motor the horizontal position. If necessary, vertical motors with suitable bearings are supplied by the manufacturing plant in the horizontal position.

Note

Place the machine in a secure and raised position

In order to obtain easy and safe access to the underside of the machine, place it in a secure and raised position.

 **DANGER**

Standing under suspended loads

If the lifting gear or load handling attachments were to fail, the machine could fall. This can result in death, serious injury or material damage.

Never remain under or in the immediate vicinity of the machine when it is raised.

4.8.8 Storage

If the machine is not going to be commissioned soon after delivery, ensure that it is stored correctly.

NOTICE
Seizure damage to bearings
If the machine is stored incorrectly there is a risk that the bearings will suffer damage while out of use. Examples of resulting damage can include scoring and corrosion.
Read the following storage instructions.

Preconditions and preparations

- Only store goods in undamaged packaging. If goods are delivered in damaged packaging, unpack them and store appropriately according to the nature of the goods.
- Repair any damage to the packaging before putting the equipment into storage insofar as this is necessary to ensure proper storage conditions.

General instructions for storage

Wherever possible, store the machine in a storage room. The place of storage must satisfy the following general conditions:

- Select a sufficiently sized dry and horizontal place of storage that is above flood level and free of vibration ($v_{\text{eff}} \leq 0.2 \text{ mm/s}$).
 - The place of storage must be well ventilated as well as free of dust and frost. Provide protection against extreme weather conditions. Ensure that the temperature remains stable in the range from 10° C (50° F) to 50° C (120° F). The room temperature should be approx. 10 K above the outside temperature. The temperature should not fall below -20° C.
 - The relative humidity of the air should be less than 60%.
 - The floor of the place of storage must be sufficiently strong. The maximum permissible floor loading or storage compartment loading may not be exceeded.
 - The ambient air must not contain any harmful gases.
- Protect the motor from shocks and humidity.
- Position machines, devices and crates on pallets, wooden beams or foundations that protect them against rising damp and water.
- Ensure that the air circulation under the equipment is not impeded.
 - Place wooden spacer blocks between the covers and the motor.
 - Covers or tarpaulins must not trail on the floor around the machine.

Storing outdoors

For outdoor storage, the following additional conditions must be satisfied:

- The ground must be sufficiently strong. Prevent the motor from sinking into the ground.
- Covers or tarpaulins used to protect the equipment against the weather must not make contact with the surfaces of the equipment. Otherwise air circulation under the stored items will be prevented.

Protection against humidity

If a dry storage space is not available, protect the machine as follows against humidity:

- Wrap the machine in humidity-absorbent material.
- Wrap the machine in plastic film:
 - Place a humidity meter inside the plastic film.
 - Place desiccant within the plastic film.
 - Pack the machine air-tight.
- Inspect the machine regularly.

If you do not intend to commission the machine immediately, take the following precautions:

- Always keep the terminal box's cover tightly sealed.
- Do not remove the rotor shipping brace device supplied.
- Open the pressure fingers of the brush holders. Take the brushes out of the holders.
- If necessary, reapply the anti-corrosion protection at the shaft extension.

Long-term storage

If you are storing a machine for more than six months, you must check its condition every six months. Store the machine in accordance with the specifications in Section "Storage (Page 32)", and if possible, packed.

- Check the motor for damage.
- Carry out any necessary maintenance work.
- Make sure that the storage conditions are such that condensation cannot form in the motor.
- If the machine is not sealed in plastic film, continually and slightly heat the machine, e.g. with anti-condensation heating (if available), and ensure that the air circulates in the storage room.

Storage for longer than three months

Lubricate the machine after every two years of storage.

1. Unpack the machine.
2. Remove the rotor shipping brace, if one is being used.

3. When stored for longer than two years, lubricate with twice the grease quantity in accordance with the lubricant plate. This ensures that the grease is evenly distributed and covers all surfaces. Corrosion damage is avoided.

NOTICE
Damage to roller bearings
Roller bearings can be damaged when kept in the same or almost the same position. Every three months, manually rotate the rotor through five revolutions. Make sure that the resting position of the roller bearings after the rotor has been turned is different from what it previously had been. Use the feather key as a reference point, if present.

4. Replace the corrosion protection.
5. Reattach the rotor shipping brace, if present.
6. Pack the machine again.

4.8.9 Protection against corrosion

If the machine is stored in dry conditions, then apply the subsequently listed anti-corrosion measures:

- Storage up to six months:
Apply a coat of corrosion protective compound to all accessible bare metal parts such as the exposed shaft extension, flange or machine feet.
- Storage for longer than six months:
Apply a coat of anti-corrosion compound which provides long-term protection, e.g. Tectyl 506.
- Inspect the machine regularly and apply an additional coating of corrosion protection if necessary.

Document all preservation measures taken so that they can be reversed before the machines are put back into service.

Assembling

When carrying out any work on the machine, observe the general safety instructions (Page 15) and the specifications contained in EN 50110-1 regarding safe operation of electrical equipment.

5.1 Preparations for installation

5.1.1 Requirements for installation

The following requirements must be satisfied prior to starting installation work:

- Staff have access to the operating and installation instructions.
- The machine is unpacked and ready for mounting at the installation location.

Note

Measure the insulation resistance of the winding before starting installation work

Wherever possible, measure the insulation resistance of the winding before starting installation work. If the insulation resistance lies below the specified value, take appropriate remedial measures. These remedial measures may necessitate the machine being removed again and transported.

NOTICE
<p>High temperatures</p> <p>The motor components get very hot during operation. High temperatures can damage mounting parts such as the cable insulation.</p> <ul style="list-style-type: none"> • Temperature-sensitive parts such as normal cables or electronic components must not rest against or be attached to mounted machine parts. • Only use heat-resistant mounting parts. The connecting cables and cable entries must be suitable for the ambient temperature.

Note

Loss of conformity with European directives

In the delivery state, the machine corresponds to the requirements of the European directives. Unauthorized changes or modifications to the machine lead to the loss of conformity with European directives and the loss of warranty.

5.1.2 Insulation resistance and polarization index

Measuring the insulation resistance and polarization index (PI) provides information on the condition of the machine. It is therefore important to check the insulation resistance and the polarization index at the following times:

- Before starting up a machine for the first time
- After an extended period in storage or downtime
- Within the scope of maintenance work

The following information is provided regarding the state of the winding insulation:

- Is the winding head insulation conductively contaminated?
- Has the winding insulation absorbed moisture?

As such, you can determine whether the machine needs commissioning or any necessary measures such as cleaning and/or drying the winding:

- Can the machine be put into operation?
- Must the windings be cleaned or dried?

Detailed information on testing and the limit values can be found here:

"Testing the insulation resistance and polarization index" (Page 36)

5.1.3 Testing the insulation resistance and polarization index



 WARNING
Hazardous voltage at the terminals
During and immediately after measuring the insulation resistance or the polarization index (PI) of the stator winding, hazardous voltages may be present at some of the terminals. Contact with these can result in death, serious injury or material damage.
<ul style="list-style-type: none">• If any power cables are connected, check to make sure line supply voltage cannot be delivered.• Discharge the winding after measurement until the risk is eliminated, e.g. using the following measures:<ul style="list-style-type: none">– Connect the terminals with the ground potential until the recharge voltage drops to a non-hazardous level– Attach the connection cable.

Measure the insulation resistance

1. Before you begin measuring the insulation resistance, please read the operating manual for the insulation resistance meter you are going to use.
2. Make sure that no power cables are connected.

3. Measure the winding temperature and the insulation resistance of the winding in relation to the machine enclosure. The winding temperature should not exceed 40° C during the measurement. Convert the measured insulation resistances in accordance with the formula to the reference temperature of 40° C. This thereby ensures that the minimum values specified can be compared.
4. Read out the insulation resistance one minute after applying the measuring voltage.

Limit values for the stator winding insulation resistance

The following table specifies the measuring voltage and limit values for the insulation resistance. These values correspond to IEEE 43-2000 recommendations.

Table 5-1 Stator winding insulation resistance at 40° C

V_N [V]	V_{Meas} [V]	R_C [MΩ]
$U \leq 1000$	500	≥ 5
$1000 \leq U \leq 2500$	500 (max. 1000)	100
$2500 < U \leq 5000$	1000 (max. 2500)	
$5000 < U \leq 12000$	2500 (max. 5000)	
$U > 12000$	5000 (max. 10000)	

U_{rated} = rated voltage, see the rating plate

U_{meas} = DC measuring voltage

R_C = minimum insulation resistance at reference temperature of 40° C

Conversion to the reference temperature

When measuring with winding temperatures other than 40° C, convert the measuring value to the reference temperature of 40° C according to the following equations from IEEE 43-2000.

(1)	R_C	Insulation resistance converted to 40° C reference temperature
	k_T	Temperature coefficient according to equation (2)
	R_T	Measured insulation resistance for measuring/winding temperature T in °C
$R_C = K_T \cdot R_T$		
(2)	40	Reference temperature in °C
	10	Halving/doubling of the insulation resistance with 10 K
	T	Measuring/winding temperature in °C
$K_T = (0.5)^{(40-T)/10}$		

In this case, doubling or halving the insulation resistance at a temperature change of 10 K is used as the basis.

- The insulation resistance halves every time the temperature rises by 10 K.
- The resistance doubles every time the temperature falls by 10 K.

5.1 Preparations for installation

For a winding temperature of approx. 25° C, the minimum insulation resistances are 20 MΩ (U ≤ 1000 V) or 300 MΩ (U > 1000 V). The values apply for the complete winding to ground. Twice the minimum values apply to the measurement of individual assemblies.

- Dry, new windings have an insulation resistance of between 100 and 2000 MΩ, or possibly even higher values. An insulation resistance value close to the minimum value could be due to moisture and/or dirt accumulation. The size of the winding, the rated voltage and other characteristics affect the insulation resistance and may need to be taken into account when determining measures.
- Over its operating lifetime, the motor winding insulation resistance can drop due to ambient and operational influences. Calculate the critical insulation resistance value depending on the rated voltage by multiplying the rated voltage (kV) by the specific critical resistance value. Convert the value for the current winding temperature at the time of measurement, see above table.

Measuring the polarization index

1. To determine the polarization index, measure the insulation resistances after one minute and ten minutes.

2. Express the measured values as a ratio:

$$PI = R_{\text{insul } 10 \text{ min}} / R_{\text{insul } 1 \text{ min}}$$

Many measuring devices display these values automatically following the measurement.

For insulation resistances > 5000 MΩ, the measurement of the PI is no longer meaningful and consequently not included in the assessment.

$R_{(10 \text{ min})} / R_{(1 \text{ min})}$	Assessment
≥ 2	Insulation in good condition
< 2	Dependent on the complete diagnosis of the insulation

NOTICE

Damage to insulation

If the critical insulation resistance is reached or undershot, this can damage the insulation and cause voltage flashovers.

- Contact the Service Center (Page 137).
- If the measured value is close to the critical value, you must subsequently check the insulation resistance at shorter intervals.

Limit values of the anti-condensation heating insulation resistance

The insulation resistance of the anti-condensation heating with respect to the machine housing should not be lower than 1 MΩ when measured at 500 V DC.

5.1.4 Preparing the mating faces

Prepare the foundation faces dependent on the machine type:

- Mounting on a foundation
 - Ensure that the foundation faces are flat and free of contaminations.
 - Check the dimensions of the mounting-foot holes.
- Flange connection
 - Clean the flange before installation. Ensure that the flange surfaces are flat and perfectly clean.
 - Check the geometry of the flange.
- Wall mounting
 - Ensure that the wall faces are flat and free of contaminations.
 - Check the dimensions of the mounting-foot holes.
 - Support the machine from below, e.g. using a wall bracket or by bolting it.

Note**Wall mounting**

Machines that are attached to the wall by their mounting feet because of their type of construction must be supported from below by a wall strip, for example, or bolted.

5.2 Lift the machine to where it will be installed, and position it

5.2.1 Preconditions for correct alignment and secure attachment

Detailed specialist knowledge of the following measures is required in order to correctly align and securely fit the equipment.

- Preparing the foundation
- Selecting and mounting the coupling
- Measuring the concentricity and axial eccentricity tolerances
- Positioning the machine

If you are not familiar with the prescribed measures and procedures, then you can make use of the services offered by the local Service Center (Page 137).

5.2.2 Checking the load handling attachments

Inspect the load handling attachments such as the load stands, lifting eyes and ring bolts and also the lifting gear, before lifting the machine:

- Inspect the load handling attachments on the machine for possible damage. Replace any load handling attachments that are found to be damaged.
- Check before use that the load handling attachments are correctly secured.
- When lifting the machine, use only approved and undamaged lifting gear of sufficient rated capacity. Check these before using them.

 WARNING
The machine can be dropped
If the load handling attachments and lifting gear are damaged or not correctly secured, the machine may be dropped during lifting. This can result in death, serious injury or material damage. Inspect the load handling attachments and lifting gear before use.

5.2.3 Removing the rotor shipping brace

If a rotor shipping brace is attached to the machine, remove it at the last possible moment, for example, when you are ready to push on the output or drive element.

Note

Store the rotor locking device

Be sure to store the rotor locking device. It must be remounted for possible disassembly and transport.

NOTICE
Damage to the bearing
Dismantling the rotor shipping brace when the machine is in a horizontal position could damage the bearings.
Only remove the rotor shipping brace when the machine is in a vertical position.

NOTICE
Damage to the bearing
Failure to fit the rotor shipping brace can result in damage to the bearings while the machine is being turned onto its side.
Fix the rotor in place before you turn the machine into a horizontal position.

5.2.4 Removing anti-corrosion protection

Machined, bright surfaces of machine parts and small components such as screws, bolts, wedges, feather keys and dowel pins, are treated with an anti-corrosion agent.

Carefully remove the anti-corrosion agent just before starting the installation work.

Bright surfaces on machine parts

- Use petroleum, petroleum ether, or a similar solvent or detergent to remove the anti-corrosion coating from the machined surfaces of machine parts and from small components.

NOTICE
Paintwork damage
If painted surfaces come into contact with the detergent or solvent, the paintwork can be damaged.

- Use a suitable solvent to soften thick layers of anti-corrosion agent. Then push the softened layers off using a piece of hardwood approximately 10 x 10 x 1 cm. Do not sand the protective coating down or scrape it off.

NOTICE
Damage to the machine surface
If you use metal objects such as scrapers, spatulas, or plates to remove the anti-corrosion protection, this could result in damage to the surfaces of the machine parts.

- Lightly oil the depreserved surfaces.

5.2.5 Mounting the output elements

Balance quality

The rotor is dynamically balanced. For shaft extensions with featherkeys, the balancing type is specified using the following coding on the face of the drive end of the shaft:

- "H" means balancing with a half feather key
- "F" means balancing with a whole feather key.



Image 5-1 Balancing type on the drive-end side

Pushing on the power output elements

- Prerequisites:
 - The coupling and/or the output element must be appropriately dimensioned for the operating case at hand. The balance quality must satisfy the following requirements.
 - Comply with the coupling manufacturer's instructions.
 - Make sure that the balancing type of the transmission element correctly matches the type of balance of the rotor.
 - Use only ready drilled and balanced transmission elements. Check the hole diameters and the balancing status before pulling them on. Thoroughly clean the shaft extension.
- Pulling on:
 - Warm up the transmission elements to expand them before pulling them on. Select the temperature difference for the heating process to suit the coupling diameter, fit and material. See the coupling manufacturer's instructions.
 - Power output elements may only be pushed on or pulled off with the correct equipment. The transmission element must be pulled on in one continuous operation via the front thread holes in the shaft or pushed on by hand.
 - Do not strike it with a hammer, as this would damage the bearings.

Shaft extensions with feather key

To maintain the balancing quality, you have the following options:

- If the transmission element is shorter than the feather key with balancing type "H", you must machine off the section of feather key protruding from the shaft contour and transmission element in order to maintain the balance quality.
- If the transmission element is drawn up on to the shoulder of the shaft, you must ensure that the part of the coupling groove where the feather key is not inserted is taken into consideration when balancing the coupling.
- The feather key must be shortened if the coupling hub is shorter than the feather key.
- The center of gravity of the coupling half should be within the length of the shaft end.
- The coupling used must be prepared for system balancing.
The number of poles of the machine is specified on the rating plate (in the designation of the motor type).



WARNING

The feather key can fall out

The feather keys are only locked against falling out during shipping. If a machine with two shaft extensions does not have an output element on one shaft extension, the feather key can fall out during operation.

Death or serious injury can result.

- Do not operate the machine unless the transmission elements have been pulled on.
- On shaft extensions without output element, make sure that the feather key cannot fall out and shorten it by approximately half for balance type "H".

5.2.6 Lifting and transporting the machine

To safely lift and transport the machine, the following requirements must be met:

- Personnel operating cranes and fork-lift trucks must be appropriately qualified.
- When lifting the machine, use only approved and undamaged sling guides and spreaders of sufficient rated capacity. Check the lifting equipment prior to its use. The weight of the machine is shown on the rating plate.
- When lifting the machine, refer to the information on the lifting plate.
 - Comply with the specified spreading angles.
 - Do not exceed the maximum lifting acceleration and lifting speed specified on the lifting plate. Lift the machine without jerking it.
Acceleration $a \leq 0.4 \text{ g}$ ($\approx 4 \text{ m/s}^2$)
Velocity $v \leq 20 \text{ m/min}$
- Use only the load carrying device on the stator frame for lifting.

5.2 Lift the machine to where it will be installed, and position it

 WARNING
The machine can tip over, slip or fall down during transport if a different construction is used
If you do not transport or lift the machine in a position appropriate for its construction, the machine can tip, slip into the lifting equipment or fall down. This can result in death, serious injury or material damage.
<ul style="list-style-type: none">• Use only the load carrying device on the stator frame for lifting.• Use the load carrying device appropriate for the machine position.• Use suitable rope guiding or spreading devices. The weight of the machine is shown on the rating plate.

 WARNING
The machine can fall over, shift or fall down during transport if the center of gravity is not symmetrical
If the center of gravity of a load is not located centrally between the attachment points, the motor can tip over or slip out of the lifting equipment and fall when it is being transported or lifted. This can result in death, serious injury or material damage.
<ul style="list-style-type: none">• Comply with the handling instructions on the machine when transporting it.• Be aware of the possibility of different loads on the sling ropes or lifting straps and the carrying capacity of the lifting equipment.• Always take account of the center of gravity when transporting or lifting the motor. If the center of gravity is not located centrally between the attachment points, then position the hoisting hook above the center of gravity.

Note

Place the machine in a secure and raised position

In order to obtain easy and safe access to the underside of the machine, place it in a secure and raised position.

 DANGER
Standing under suspended loads
If the lifting gear or load handling attachments were to fail, the machine could fall. This can result in death, serious injury or material damage.
Never remain under or in the immediate vicinity of the machine when it is raised.

5.2.7 Putting the machine down

Requirements

The following preconditions must be satisfied before setting down the machine at the installation location:

- The mating faces must be clean.
- The anti-corrosion protection paint has been removed from the mating faces, such as the machine mounting feet, flange, ...
- There is no condensation present within the machine.

Setting down the machine

- Set down the machine slowly and carefully at the installation location to avoid any impact.

5.2.8 Drain condensate

In the bearing shields at the DE and NDE, water drain holes are situated in the foot area and opposite the regreasing system. They are designed as follows:

- IP23 degree of protection: Water drain holes open
- IP54 / IP55 degree of protection: Water drain holes sealed with plastic plugs

Where drain holes in the foot area are sealed, it can be useful to remove the appropriate screws or plugs depending on the ambient and operational conditions.

Note

Degree of protection for motors with IP54 and better

Removing the plastic plug or the plug screw from motors with IP54 or better nominally lowers the degree of protection to IP44.

5.2.9 Roughly aligning the machine

Requirement

The transmission element such as a coupling half has already been pulled on.

Roughly aligning the machine

- For horizontal positioning, push the motor sideways across the foundation. When doing so, ensure that the axial position is maintained.

5.3 Installing the machine

Note

Service Center

For any installation work that is required, contact the Service Center (Page 137) or commission service engineers trained by Siemens and authorized for this task.

5.3.1 Safety instructions for installation

 WARNING
Inappropriate fastening material If screws of an incorrect property class have been selected or if they have been fastened to an incorrect tightening torque, they may break or become loose. This will cause the machine to move, which could damage the bearings. The rotor could smash into the machine enclosure and machine parts could be flung out of place. This can result in death, serious injury or material damage. <ul style="list-style-type: none">• Comply with the required property classes for screwed connections.• Tighten the screwed connections to the specified tightening torques.

 WARNING
Incorrect alignment If the machine has not been properly aligned, this will mean the fastening parts are subjected to stress/distortion. Screws may become loose or break, the machine will move, machine parts could be flung out of place. This can result in death, serious injury or material damage. <ul style="list-style-type: none">• Carefully align the machine to the driven machine.

NOTICE
Improper handling Mounting parts such as temperature sensors or speed sensors are attached to the machine and could be ripped off or destroyed as a result of improper handling. This could lead to machine malfunctions, extending even to total loss of the machine. <ul style="list-style-type: none">• Where necessary, use suitable steps when performing installation work on the machine.• Do not stand on cables or attachments during installation. Do not use attachments as steps.

5.3.2 Selecting fixing screws

- Unless specified otherwise, use mounting bolts with at least strength class 8.8 to ISO 898-1. In this way you guarantee that the machine is securely mounted and the forces can be transferred through the torque.
- Take into account the maximum forces occurring in the case of a fault such as short circuit or system transfers in phase opposition.
 - When selecting the bolts
 - When designing the foundation

5.3.3 Preconditions for smooth, vibration-free operation

Preconditions for smooth, vibration-free operation:

- Stable foundation design
- Precise alignment of the machine
- Correct balancing of parts to be fitted to the shaft end.
- Maintaining the vibration velocity according to ISO 10816-3

5.3.4 Aligning the machine to the driven machine and attaching it to it (foundation mounting)

1. Refer to any instructions for aligning the driven machine and those of the coupling manufacturer.
2. Align the machines with coupling output to the driven machine in such a manner that the center lines of the shafts at the operating temperature do not have any parallel or angular offset. This ensures that no additional forces affect their bearings during operation. If the thermal change of the motor and the driven machine is different, couple in the cold state with an appropriate alignment offset. The alignment offset to be set in the cold state must be determined and specified by the system specialist.
3. For the vertical positioning ($x \rightarrow 0$), place thin shims over a large surface area under the machine feet. The number of shims should be kept as low as possible, i.e. stack as few as possible. This also prevents the machine being subjected to any stress/distortion. Use the existing tapped holes for the forcing-off bolts to raise the machine. The balance state of the shaft (full-key or half-key balancing) and alignment errors primarily influence the service life of the bearing, especially for high motor speeds or when using rigid couplings.

5.3 Installing the machine

4. When positioning the machine, ensure that a uniform axial gap ($y \rightarrow 0$) is maintained around the coupling.
5. Fix the machine to the foundation. The choice of fixing elements depends on the foundation and is the plant operator's responsibility.

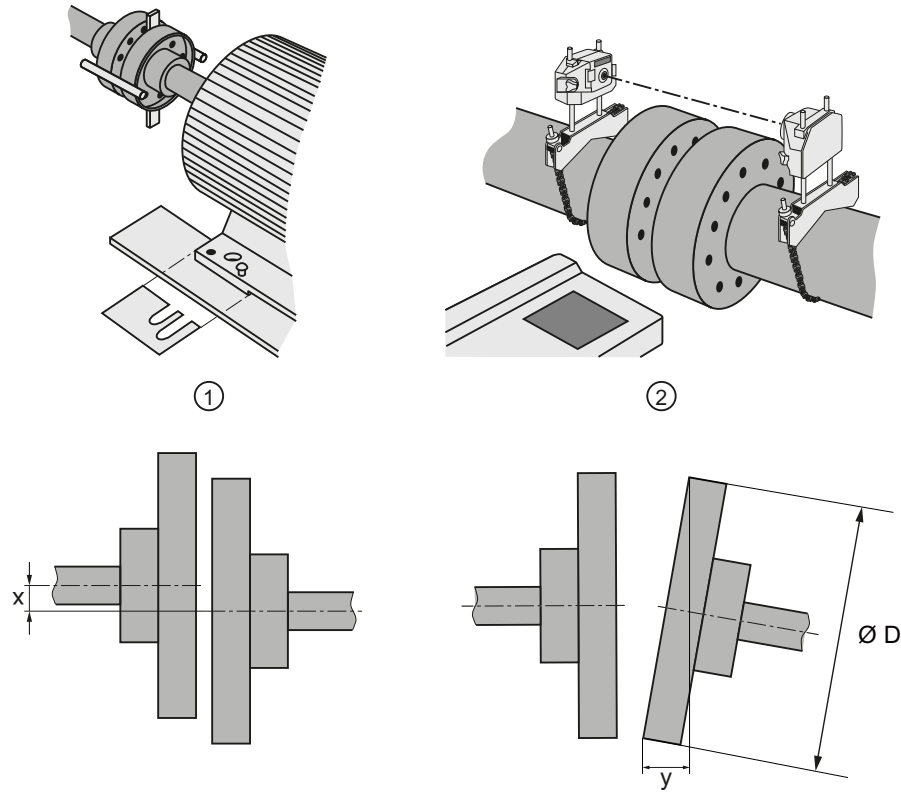

- ① Plates placed under the motor for alignment
- ② Laser alignment

Image 5-2 Schematic diagram: Aligning the machine to the driven machine

Table 5-2 Permissible deviations for aligning the machine with flexible coupling

Max. speed n_{max}	Max. parallel offset x	Max. angular offset y
$n_{max} \leq 1500$ rpm	$x_{max} = 0.08$ mm	$y_{max} = 0.08$ mm / 100 mm $\varnothing D$
1500 rpm $< n_{max} \leq 3600$ rpm	$x_{max} = 0.05$ mm	$y_{max} = 0.05$ mm / 100 mm $\varnothing D$

Note

Machine expansion

When performing alignment, make allowance for the thermal expansion of the machine due to rising temperature.

5.3.5 Aligning the machine to the driven machine and attaching it to it (flange mounting, vertical)

The standard flange is provided with a centering. The choice of fit for the mating flange on the driven machine is the system manufacturer's or the plant operator's responsibility.

Note

If the machine is not fitted with a standard flange, align the machine to suit the driven machine.

Procedure

The machine axis must be vertical when it is lifted and the flange must be parallel to the mating flange, so as to avoid seizing and stressing. Otherwise damage to the centering will result.

1. Grease the centering flange with assembly paste to make the process easier.
2. Screw in two studs into tapped holes on opposite sides of the driven machine flange. The studs act as positioning aids.
3. Lower the machine slowly toward the driven machine and into the centering, so that the flanges do not quite touch. Lowering too quickly risks damaging the centering.
4. If necessary, rotate the machine into the right position so that the clearance holes in the flange are central to the tapped holes.
5. Lower the machine completely onto the mating flange so that it is fully in contact; then remove the studs.
6. Fix the machine using the flange fixing bolts.

See also

Technical data and drawings (Page 139)

5.3.6 Aligning the machine to the driven machine and mounting (flange, horizontal IM B5)

The standard flange is provided with a centering. The choice of fit for the mating flange on the driven machine is the system manufacturer's or the plant operator's responsibility.

Note

If the machine is not fitted with a standard flange, align the machine to suit the driven machine.

Procedure

The machine axis must be horizontal when it is lifted and the flange must be parallel to the mating flange, so as to avoid seizing and stressing. Otherwise damage to the centering will result.

1. Grease the centering flange with assembly paste to make the process easier.
2. Screw three studs into tapped holes spaced about 120° apart around the driven machine flange. The studs act as positioning aids.
3. Position the machine so that its axis is aligned with that of the driven machine, but not yet quite touching. Advance the machine slowly towards the driven machine; advancing too quickly risks damaging the centering.
4. If necessary, rotate the machine into the right position so that the clearance holes in the flange are central to the tapped holes.
5. Move the machine fully up against the mating flange so that it is fully in contact.
6. Fix the machine using the flange fixing bolts, finishing by replacing the studs.

See also

Technical data and drawings (Page 139)

5.3.7 Mounting the machine

Secure mounting of different motor variants

- For secure motor mounting, use fastening screws with the required property class per ISO 898-1, e.g. 10.9.
- On motors with an upwardly oriented shaft extension, make sure that no water enters the top bearing.
- Machines that are attached to the wall by their mounting feet because of their type must be supported from below by a wall strip, for example, or pinned.
- Install motors with a belt output on clamping bars. This provides a simple way of ensuring the correct belt tension.

Alignment accuracy

The coaxial characteristic of the shafts of electrical machines and driven machine may not exceed 0.05 mm in diameter.

5.3.8 Axial and radial forces

You can obtain the permissible values for axial and radial forces by contacting the Siemens Service Center (Page 137) or referring to the machine catalog.

NOTICE**Damage to bearings or the shaft**

Large output masses and their centers of gravity outside the shaft extensions can lead to resonance in operation. This can result in damage to the bearings and shaft.

Ensure that the permissible loads for the forces on the shaft extension are adhered to in accordance with the catalog data or configuration data.

- Use tensioning rails to set up belt-driven motors to adjust the belt to the correct tension.

 **CAUTION**
Excessive belt tension

On machines with a belt pulley, the bearings and shaft can be damaged if the belt tension is too high.

It is essential, therefore, that the radial and axial shaft load values are within tolerance.

5.4 Ensuring cooling by means of external fans

The machine is cooled by an external fan independently of its speed. The following conditions apply:

- The cooling air must enter unimpeded through the air inlets and be discharged unimpeded through the air outlets.
- Expelled air is not drawn back in immediately.
- The cooling air must be clean.
- The direction of the air flow in the motor is stated on the rating plate. Do not change the direction of ventilation without first asking for advice because it may make derating necessary. In the case of motors with winding temperature monitoring, the temperature monitor may cease to function if the air-flow direction is subsequently changed.
- If ventilation openings are covered by louvered covers, the openings of the louvered covers must be directed downward to maintain the degree of protection.
- If the ventilation openings are directed upward, protect the openings with sufficiently large covers at an appropriate distance from the openings.
- On closed-circuit-cooled motors with a pipe connection or external fan, you must choose and connect suitable pipes, external fans, and air ducts. With the IC 37 cooling method, replace the louvered covers on unused openings with closed covers.
- Where a pipe connection is used, comply with the specifications for cooling air flow rate and cooling air direction stated on the rating plate.
- In the case of motors with a built-on external fan or with an air-to-air or air-to-water heat exchanger, the relevant operating instructions must be observed.
- Do not use materials containing silicone to seal the air inlet ducts and machine elements.

5.4 Ensuring cooling by means of external fans

- If you need to change the position of the external fan, reposition the louvered covers, filters, and sound absorbers in such a way that the cooling efficiency and degree of protection are maintained.
- Please observe the following for side-mounted external fans:
 - External fans are supplied separately.
 - Do not mount the external fan until the foot bolts have been finally tightened.
 - Ensure the external fan is supported, if necessary.

Electrical connection

When carrying out any work on the machine, observe the general safety instructions (Page 15) and the specifications contained in EN 50110-1 regarding safe operation of electrical equipment.

6.1 Selecting cables

Take the following criteria into account when selecting the connecting cables:

- Rated current
- Rated voltage
- If required, service factor
- System-dependent conditions, such as ambient temperature, routing type, cable cross-section as defined by required length of cable, etc.
- Configuration notes
- Requirements according to IEC/EN 60204-1

6.2 Bringing in and routing the cables

1. The screw-mounted entry plate is not normally supplied with holes. Make sure the type, number, and size of the screw connections are appropriate to the specific cabling requirements.
2. Only use guide elements that meet the following requirements:
 - Guide elements must be adapted to suit the type and diameter of the cables.
 - Guide elements must guarantee IP55 degree of protection. The same applies to insertion points, where sealing rings and adhesive should be used.
 - Guide elements must be appropriate to cable installation conditions. For example, use cable grips where cables are not securely installed.
3. Avoid chafing the cable insulation. Route the connecting cables and, in particular, the protective conductors in the terminal box so that they do not touch the machine and excess length remains.
4. Close unused cable entries with suitable seal inserts. Please ensure the following:
 - The seals are made of resistant, approved material.
 - The degree of protection is guaranteed. Use sealing rings or adhesive, if necessary
 - Only open the cable entries with a tool.

6.3 Terminal designations

According to IEC / EN 60034-8, the following basic definitions apply to the terminal designations on DC motors:

Table 6-1 Terminal designations in example B1

B	1	Designation
x		Code letter for winding parts (A, B, C, D, E, F)
	x	Identification number showing winding start (1), end (2), or tapping if there is more than one connection per winding

The terminal diagram pasted into the terminal box shows only the conditions required for connection to the line power supply, without detailed representation of inner connections or winding components.

6.4 Connecting cables

The power cables are connected in the terminal box. Supplementary connections for auxiliary circuits with terminal strips for cable cross-sections of up to 2.5 mm² are provided. Terminal post insulators or Terminal Boards (depending on construction type) are provided for connecting the excitation circuit.

- Terminal boxes can also be rotated by 90° in each case depending on the connecting direction. Please ensure that winding feeder cables are relaid correctly. In this case, the insulator plate does not need to be repositioned. Under difficult conditions, e.g. with large cross sections or a large number of cables, repositioning a terminal box may only be possible with restrictions or special adaptation steps may be necessary.
- Connect the cables in such a way as to ensure a permanent and reliable electrical connection. Depending on their design, the connecting parts may be suitable for connection with or without cable lugs. Use the matching cable end pieces.
- Make sure the protective conductor connection is secure.
- Comply with the rating plate data and the terminal diagram in the terminal box when making the electrical connections.

6.5 Connecting the main circuit

Requirements

- Remove the insulation from the conductor ends so that the remaining insulation is almost long enough to reach the cable lug.
- Insulate the cable lug sleeves to ensure minimum air clearances are maintained.

Voltage	Minimum air clearance
Up to 600 V	> 8 mm
Up to 800 V	> 10 mm
Up to 1200 V	> 14 mm

 WARNING
Short circuits caused by projecting wire ends
The minimum air clearance may be reduced by projecting wire ends. This can result in short circuits. This can result in death, serious injury or material damage.
Remove protruding cables. Ensure that minimum air clearances as specified in the table above are maintained.

Connecting using cable lugs

1. Select the cable lugs corresponding to the required cable cross-section and the specified dimensions of the terminal connection.
2. Tighten the contact and fastening nuts to the torque specified in the table below:

Table 6-2 Terminal box connection data

Terminals		1XB7	gk 602 / gk 604	gk 702 / gk 704
Main terminals	Terminal size	M16	M10	M12
	Tightening torque	83 Nm	13 Nm	20 Nm
	Connectable cable cross-section	6 x 240 mm ²	2 x 35 mm ²	2 x 70 mm ²
Auxiliary terminals	Terminal size	M6	M4	M4
	Tightening torque	4 Nm	1.2 Nm	1.2 Nm
	Connectable cable cross-section	35 mm ²	6 mm ²	6 mm ²

6.5 Connecting the main circuit

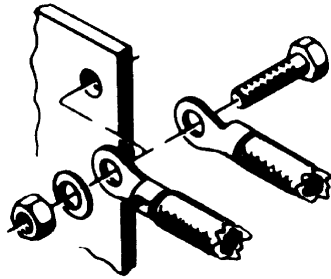

Image 6-1 Connection of main terminals with cable lug

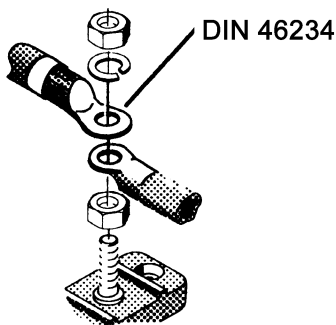

Image 6-2 Connection of auxiliary terminals with cable lug

- If the fastening elements for connection to busbars were not supplied, use only permissible fastening elements. For example, use corrosion-protected hexagon-head bolts with at least property class 5.6 per DIN 43673 with hexagonal nuts and spring-lock elements, e.g. spring washers per DIN 128.

Connection without cable lugs

If terminal box size gk 602 or gk 702 is mounted on the machine, you can also connect the cables without cable lugs.

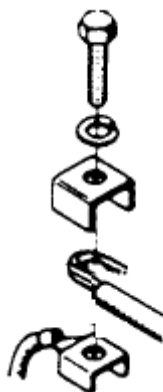



Image 6-3 Connection without cable lugs

- The design of the terminals makes it possible to connect finely stranded conductors without the use of wire end ferrules.
- Use only wire end ferrules that have been properly crimped onto the conductor so that the full terminal clamping force holds the conductor in place. Stiff wire end ferrules, which have not yet been placed under pressure, reduce the binding power exerted on the conductor, thereby affecting the quality of the contact.

6.6 Connecting the grounding conductor

The grounding conductor cross-section of the machine must match the installation specifications, e.g. comply with IEC / EN 60204-1.

	CAUTION
Damage resulting from protective conductor currents	
During motor operation, PE conductor currents of up to 1.7 times the line current can arise if there is a ground fault on the output side. Neither the PE conductors of normally dimensioned multi-core connecting cables nor the PE connection points of normal terminal boxes are suitable for this purpose. This results in material damage.	
Install an adequately sized parallel protective conductor and connect this to the ground terminal on the motor housing. Use only the screws supplied.	

Connecting the grounding conductor

A hexagon-head bolt with a spring lock washer and plain washer or a ground terminal is provided at the designated grounding conductor connection points. The hexagon bolt can be used for connecting stranded conductors with cable lugs or ribbon cables with an appropriately shaped conductor end.

When making connections, ensure the following:

- the connecting surface is bare and protected against corrosion using a suitable substance, e.g. acid-free Vaseline
- the flat and spring washers are located under the bolt head.
- The maximum permissible clamping thickness of 10 mm for the cable lug or strap is not exceeded
- The minimum required screw-in depth and the tightening torque comply with the values specified in the tables below. Different values apply to cable lugs or grounding terminals.

Table 6-3 Tightening torque of screws with cable lugs

Bolt	Screw-in depth	Tightening torque
M12 x 25	> 16 mm	38 Nm
M16 x 35	> 20 mm	92 Nm

6.8 Connecting the auxiliary circuits

Table 6-4 Tightening torque of screws with ground terminals

Bolt	Screw-in depth	Tightening torque
M6	> 9 mm	8 Nm
M8	> 12 mm	20 Nm
M10	> 15 mm	40 Nm

Equipotential bonding

Terminals are provided on the bearing shield for the connection of an equipotential bonding conductor.

6.7 Internal equipotential bonding

The equipotential bonding between the protective conductor terminal in the terminal box and the motor housing is established through the terminal box fixing screws. These screws are rated and designed as an "equivalent conductive connection" in relation to the protective conductor cross-section specified for the phase conductor in standard (IEC / EN 60034-1).

Equipotential bonding

In order to guarantee the current carrying capacity of the connection via the retaining bolts in the event of a short circuit, make sure that the following conditions are fulfilled:

- Use only original gaskets.
- The contact points underneath the bolt heads or spring lock washers must be bare metal and protected against corrosion.
- The standard cover fixing screws are an adequate equipotential bonding connection between the terminal box cover and terminal box housing.



! WARNING
Electric shock
If the equipotential bonding connection fails, parts of the machine may become live. If you touch them, you will receive an electric shock. This could result in death, serious injury or material damage.
When performing any installation work you must always take care to ensure that all equipotential bonding connections remain effective.

6.8 Connecting the auxiliary circuits

Auxiliary circuit

Terminal strips for cable cross-sections of up to 2.5 mm² are provided for connecting auxiliary circuits, e.g. temperature sensor or anti-condensation heating.

The information required to connect the auxiliary circuits is provided in the connection diagram, located on the inside of the terminal box cover, and in the machine documentation.

The required length of stripped insulation on conductors for auxiliary terminals varies: From 6 to 9 mm depending on the terminal type. When the length is correct, the bare conductor must reach the center stop in the terminal and at the same time the conductor insulation must reach the contact part of the terminal.

Brush monitoring

Signal transmitters for brush monitoring are installed, depending on the machine design.

The brush monitoring device senses the brush height limit value. Two millimeters before the minimum permissible brush height is reached, a signal is output via a switch. In normal operation and at medium speeds, you can then run your motor for another approx. 500 to 1000 hours. Replace the carbon brushes in good time.

The electrical connection requirements are shown on the terminal diagram pasted into the terminal box.

Speed sensor

Electrically connect a built-on speed sensor in situ.

Temperature monitoring

Avoid hazards due to unexpected, automatic restarting of the installation after the temperature protection has tripped. Implement this in the temperature evaluation and control.



WARNING

Automatic restart

Failure to ensure that the temperature monitoring prevents automatic restarting after the machine has cooled can result in death and serious personal injury due to hazardous voltage or rotating parts.

On machines with temperature sensors, design the temperature evaluation and control circuits in such a way that it is impossible for the machine to switch on and start to rotate automatically.

6.9 Connecting an external fan motor

Procedure

1. Connect the external fan motor as shown on the terminal diagram pasted into the terminal box. Comply with the rating plate data and follow the operating instructions.
2. The direction of rotation of the external fan must match the arrow indicating the direction of rotation. The fan impeller is visible through the air inlet point in the fan cowl on the motor. If the direction of rotation is incorrect, change it by swapping over two of the phase conductors in the terminal box of the fan motor.
3. A protective circuit must be provided for electric machines with an external fan to ensure that the main machine cannot be switched on when the fan unit is not in operation.

6.10 Connecting temperature monitoring for the stator winding

The stator winding is monitored for thermal loading by resistance thermometers embedded in the stator winding.

The connecting leads of the temperature sensors are routed to the terminal box. The switching and assignment of the terminals is shown on the terminal diagram in the auxiliary terminal box.



WARNING

Hazard due to electric shock

The installation of the temperature sensors for the winding monitoring with respect to the winding is implemented according to the requirements for basic insulation. The temperature sensor connections are located in terminal boxes, safe to touch, and have no protective separation. This is the reason that in the case of a fault, a hazardous voltage can be present at the measuring sensor cable. When touched, this can result in death, severe bodily injury and material damage.

When connecting the temperature sensor to external temperature monitoring devices, when required, apply additional measures to fully comply with the requirement "Hazard due to electric shock," see IEC 60664-1 or IEC 61800-5-1.

6.11 Completing connection work

1. Before closing the terminal box, please check that:
 - The cables and links match the terminal diagram inside the terminal box cover.
 - The electrical connections in the terminal box are tight and fully comply with the specifications in the preceding chapters.
 - The inside of the terminal box is clean and free of any cable debris.
 - All of the clamping bolts and entry parts are securely tightened. This also applies to unused terminals.
 - Minimum air clearances have been respected.
 - The connecting cables are arranged so that they do not come into contact with the machine, and the cable insulation is not damaged.
 - Any unused entry points are sealed. Only open the sealing elements with a tool.
 - All of the seals/gaskets and sealing surfaces of the terminal box are in a good condition. If the joins are sealed purely by metal sealing surfaces, these sealing surfaces must be cleaned and lightly greased again.
 - The right cable guides are fitted with respect to degree of protection, method of laying, permissible cable diameter, etc., as stated in the specifications.
 - With a U-shaped terminal box casing, the entry plate is aligned and secured in such a way that the seat for the box cover seal is continuous all the way round.
2. Then close the terminal box. Tightening torque for the cover fastening screws is 22 Nm.

When carrying out any work on the machine, observe the general safety instructions (Page 15) and the specifications contained in EN 50110-1 regarding safe operation of electrical equipment.

Note**Service Center**

Please contact the Service Center (Page 137), if you require commissioning support.

7.1 Preparing for commissioning

Once the system has been correctly installed, you should check the following prior to commissioning. It may be necessary to perform additional checks and tests in accordance with the situation specific to the particular place of installation.

- The motor has been assembled and aligned properly.
- All mounting bolts, connecting elements and electrical connections are firmly tightened.
- The operating conditions correspond to the data specified on the rating plate.
- The bearings have been regreased as appropriate for the model.
- The machine is connected so that it rotates in the direction specified
- The cover sheets have been remounted correctly to ensure effective cooling of the motor.
- The rotor is fully able to turn and does not contact other parts at any point during rotation.
- All electrical and mechanical connections are secure. The function is assured.
- Any supplementary motor monitoring devices have been correctly connected.
- Appropriately configured control and speed monitoring functions ensure that the motor cannot exceed the permissible speeds specified on the rating plate.
- If the motor is operated continuously under light-load conditions of $I < 50\%$, there is a risk of high brush wear or problems with the commutator. Please consult the manufacturer if this type of operation is intended.
The power output elements have the proper setting conditions according to type, for example:
 - Couplings are aligned and balanced.
 - The belt tension is properly adjusted if there is a belt drive.
 - Gear tooth flank play and gear tooth tip play, as well as radial play, are properly adjusted if there is a gearwheel output.
- The minimum insulation resistance values are within tolerance.
- If the bearings are insulated, the insulation has not been bridged.

7.3 Greasing the roller bearings prior to commissioning

- The grounding and equipotential bonding connections have been established correctly.
- Moving and energized parts are guarded with touch protection.
- If the second shaft extension has not been used, its featherkey has been secured to prevent it from being thrown out.
- The carbon brushes can move freely in the brush guides, and the brush levers can freely move. The spring action is identical for all carbon brushes.
- All of the brakes are operating correctly.

Force-ventilated motors

- All external fans are ready for operation and have been connected so that they rotate in the direction specified.
- The flow of cooling air is not impeded.

Commissioning converters

- Commission the converter as described in its operating instructions before commissioning the motor. Be aware of the motor parameters.
- Make sure any work done is documented on the correct checklist.

7.2 Measure the insulation resistance before commissioning

Measuring the insulation resistance and polarization index (PI) provides information on the condition of the machine. It is therefore important to check the insulation resistance and the polarization index at the following times:

- Before starting up a machine for the first time
- After an extended period in storage or downtime
- Within the scope of maintenance work

The following information is provided regarding the state of the winding insulation:

- Is the winding head insulation conductively contaminated?
- Has the winding insulation absorbed moisture?

As such, you can determine whether the machine needs commissioning or any necessary measures such as cleaning and/or drying the winding:

- Can the machine be put into operation?
- Must the windings be cleaned or dried?

Detailed information on testing and the limit values can be found here:

"Testing the insulation resistance and polarization index" (Page 36)

7.3 Greasing the roller bearings prior to commissioning

The following information assumes that the specified storage conditions have been complied with.

General specifications

- Pay attention to the instructions on the lubricant plate.
- Regrease in portions. The shaft must rotate so that the new grease can be distributed in the bearings.

Regreasing the roller bearings prior to commissioning

- If the period between delivery and commissioning is more than a year and less than four years:
 - Re-grease the roller bearings with twice the amount of grease specified on the lubricant plate.
 - Check the bearing temperature, as far as possible.

Regreasing roller bearings before commissioning

You must regrease the roller bearings under the following conditions:

- If the machine has been in storage for more than four years.
- If the machine has not been stored in accordance with the specifications in the "Storage" section.

Procedure

1. Remove the bearing, regreasing pipes, grease nipples and the bearing cap.
2. Flush out the old grease.
3. Check the bearings before regreasing. If necessary, install new bearings.
4. Lubricate the bearings and reinstall the bearing components.

See also

Transport and storage (Page 27)

7.4 Minimum radial forces for cylindrical roller bearings

Note**Maintaining the minimum radial forces**

Operating roller bearings without a load can damage them. Maintain the minimum radial forces specified when using cylindrical roller bearings.

7.5 Commissioning an external fan

Table 7-1 Minimum radial forces

Type	1G.6 16.	1G.6 1H.6 18.	1G.6 1H.6 20.	1G.6 1H.6 22.	1G.6 1H.6 25.	1G.6 1H.6 28.	1G.7 1H.7 35.	1G.7 1H.7 401 ... 1H. 7 403	1G.7 1H.7 404 ... 1H.7 405	1G.7 1H.7 45.
NU2	1.2 kN	4 kN	4.5 kN	6 kN	7.5 kN	9 kN	11 kN	14.5 kN	16.5 kN	14.5 kN
NU3	-	6 kN	7 kN	9 kN	10.5 kN	12.5 kN	-	-	-	-

7.5 Commissioning an external fan

Machines of shaft heights 250 and 280 are shipped with the air-outlet grille of the external fan motor for connection to a 50 Hz supply already fitted. The cover sheet ① for motors which operate on 60 Hz is supplied as a motor accessory.

NOTICE
Operation on 60 Hz
In operation on a 60 Hz supply, the external fan motor can overheat or burn out. If you intend to operate the external fan on a 60 Hz mains supply, then fit the cover sheet ① with the screws provided under the air-outlet grille before you commission the motor.

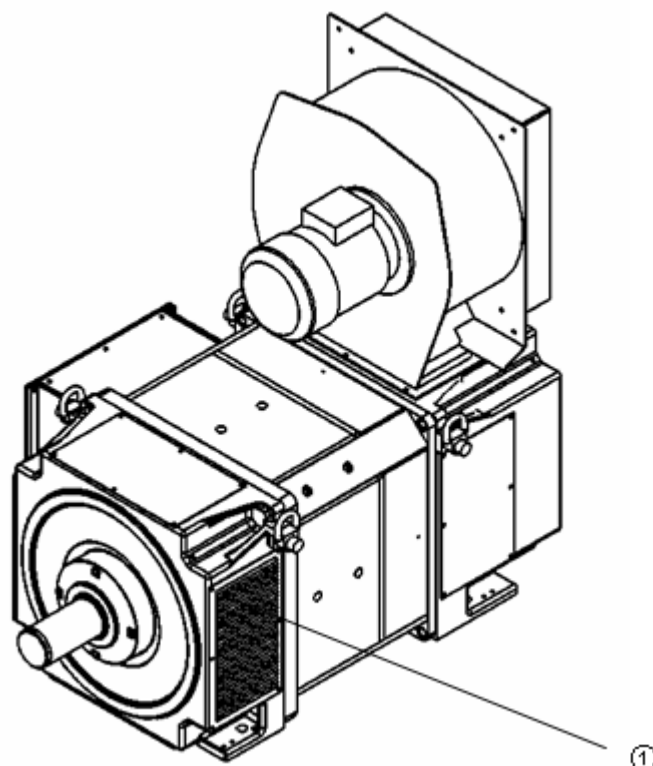

Image 7-1 External fan with cover sheet ①

7.6 Switch on

Trial run

If the period between installation and commissioning is expected to be fairly long, make sure that water-cooled machines undergo a test run without water cooling.

Procedure

- Start up the motor without a load, temporarily. Check the direction of rotation at this point.
- As the motor is coasting down, check the mechanical operation for noise and vibration at the bearings and bearing shields.
- Where the motor is running without any mechanical problems, switch it back on again. Continue to the maximum speed allowed (according to the rating plate).
- In case of uneven running or abnormal noise, switch off the machine. Determine the cause as it coasts.
- If the mechanical operation improves immediately after the motor is switched off, the cause is magnetic or electrical.

- If mechanical operation does not improve immediately after switching the motor off, the cause is mechanical, e.g. imbalance of electrical machines, etc.
- If the motor is running perfectly, switch on the cooling equipment.
- Observe the motor for a while during no-load operation.

NOTICE

Overheating during test runs without water cooling

The motor can overheat without water cooling. Reduce the ON duration accordingly if the water cooler is not to be operated during a test run.

- If it runs perfectly, connect a load.
 - Check whether it is running smoothly.
 - Record the voltage, current, and power values.
 - As far as possible, record the corresponding values of the driven machine.
 - Monitor and record the temperatures of the bearings, windings, and so on until the system reaches a steady state.

See also

Switching on (Page 144)

7.7 Overspeed

 **DANGER**

Overspeed

When the exciter circuit is deactivated, the machine can enter operating conditions that destroy the machine. Death, serious injury, or material damage will result.

- Interlock the control in such a way that the armature circuit can be connected only when the exciter circuit is energized.
- If the exciter circuit fails, switch off the armature circuit immediately.

See also

Safety notes (Page 15)

7.8 Switch off

Switch-off is usually initiated and controlled by an automatic control. If the machine is not switched off by a control, proceed as follows:

1. Switch the machine off.
2. Switch off any external fans.
3. Switch off the coolant supply. Follow the operating instructions provided by the manufacturer.
4. Switch on the anti-condensation heating.

When carrying out any work on the machine, observe the general safety instructions (Page 15) and the specifications contained in EN 50110-1 regarding safe operation of electrical equipment.





 WARNING
<p>Live parts</p> <p>Terminal boxes accommodate live parts and components. If you open the terminal box cover, this can result in death, serious injury or material damage.</p> <ul style="list-style-type: none"> • When the machine is in operation, the terminal boxes must remain closed at all times. Terminal boxes may be opened only when the machine is stopped and de-energized.



 WARNING
<p>Rotating and live parts</p> <p>Rotating or live parts are dangerous. If you remove the required covers, this can result in death, serious injury or material damage.</p> <ul style="list-style-type: none"> • Any covers that prevent live electrical or rotating parts from being touched, ensure compliance with a particular degree of protection or are required for ensuring proper air flows, and hence effective cooling, must not be opened during operation.



 WARNING
<p>Fire hazard resulting from hot surfaces</p> <p>Certain parts of the machine become hot during operation. Severe burns can result from contact with these parts.</p> <ul style="list-style-type: none"> • Check the temperature of parts before touching them. If required, apply suitable protective measures. • Allow the machine to cool before starting work on the machine.

 WARNING
<p>Faults in operation</p> <p>Deviations from normal operation such as increased power consumption, temperatures or vibrations, unusual noises or odors, tripping of monitoring devices, etc., indicate that the machine is not functioning properly. This can cause faults which can result in eventual or immediate death, serious injury or material damage.</p> <ul style="list-style-type: none"> • Immediately inform the maintenance personnel. • If you are in doubt, immediately switch off the motor, being sure to observe the system-specific safety conditions.

NOTICE
Risk of corrosion due to condensate
Humid air can condense inside the machine during operation as a result of intermittent duty or load fluctuations. Condensate can collect inside the motor. Damage such as rust can result.
<ul style="list-style-type: none">• Make sure that any condensation can drain away freely.

NOTICE
Operating the motor at the natural installation frequency
Operating the motor at the natural installation frequency can lead to damage to both the motor and the foundation.
Do not operate the motor at the natural installation frequency.

 DANGER
Overspeed
When the exciter circuit is deactivated, the machine can enter operating conditions that destroy the machine. Death, serious injury, or material damage will result.
<ul style="list-style-type: none">• Interlock the control in such a way that the armature circuit can be connected only when the exciter circuit is energized.• If the exciter circuit fails, switch off the armature circuit immediately.

8.1 Switching on the machine

Procedure

1. Run the machine without a load and check that it is running smoothly.
2. If it runs perfectly, connect a load.
3. If it is possible using the available measuring equipment, check the bearing and stator winding temperatures.

Vibration magnitudes

The vibration response of the system depends on the power output elements, orientation, and manner of installation, as well as on the influence of external vibrations. The vibration response of the system at the location where it is installed can result in greater vibration magnitudes on the motor.

The vibration magnitudes must not exceed the limits defined in DIN ISO 10816-3 as shown in the table below. This will ensure flawless commutation, low brush wear, and long bearing life.

Table 8-1 Vibration magnitude as a function of vibration frequency

Vibration frequency [Hz]	Vibration magnitudes	Vibration magnitude values	
		Frame size 280 and lower	Frame size 355 and higher
< 6.3 Hz	Vibration displacement s [mm]	≤ 0,1	≤ 0,16
6.3 to 63 Hz	Vibration speed V_{rms} [mm/s]	≤ 2,8	≤ 4,5
> 63 Hz	Vibration acceleration a [m/s ²]	≤ 1,6	≤ 2,55

If higher levels of vibration than the above specified occur in operation, special measures must be taken. For more information, please contact your local Siemens sales office.

8.2 Regreasing roller bearings

Refer to the regreasing instructions for the roller bearings on the lubricant plate.

8.3 Deactivating

- If not controlled automatically, switch on the anti-condensation heating if installed. This prevents damage to the winding insulation.
- If not controlled automatically, switch any external fans and fans off.

8.4 Switching on again after an emergency switching-off

- Check the machine before recommissioning the driven machine after an Emergency Off.
- Eliminate all the causes that have led to the emergency off

8.5 Stoppages

The stoppage is a shutdown for a period of time, during which the machine is stopped but remains at the location of use.

Under normal ambient conditions, e. g. the stopped machine is not exposed to any vibration, no increased level of corrosion, etc. in general, the following measures are necessary during stoppages.

8.5.1 Measures in non-operational periods

- Keep the motor dry using anti-condensation heating.
- After prolonged periods of non-operation and during commissioning at very low ambient temperatures ($\leq 0\text{ }^{\circ}\text{C}$), the anti-condensation heating is not sufficient. Therefore, heat the interior of the machine additionally by heating the field winding with 30 % of the rated field current without ventilation for at least 30 minutes. This will keep the interior of the motor free of ice and dry.
- Take care with motors using water cooling to avoid possible problems with corrosion and freezing. Follow the operating instructions provided by the heat exchanger manufacturer.
- During prolonged periods of non-operation, operate the motor regularly, at least once monthly. Alternatively, turn the rotor as a minimum.

NOTICE
Bearing damage due to external factors
Where cylindrical-roller bearings are used, bearing damage can be caused by external vibration.
Consult the manufacturer for details of suitable corrective action.

NOTICE
Damage due to improper storage
Damage may occur to the motor if it is not stored properly.
If the machine is to be taken out of operation for more than 12 months, suitable anti-corrosion, preservation, packaging, and drying measures must be taken.

Decommissioning

You will find detailed information about the necessary measures to be taken in the "Transportation and storage (Page 27)" section.

Recommissioning

- When restarting the motor after a long period of non-operation, perform the measures recommended in section "Commissioning (Page 63)."
- If the machine has been non-operational for longer than a year, regrease the bearings before commissioning. Turn the shaft to distribute the grease in the bearings.
- Pay attention to the instructions on the lubricant plate.

8.5.2 Avoidance of damage to roller bearings during stoppages

Extended stoppages at the identical or almost identical resting position of the roller bearings can lead to damage such as brinelling or formation of corrosion.

- During stoppages, regularly start the machine up for a brief period once a month, or at least turn the rotor over several times.
If you have uncoupled the machine from the driven machine and secured the rotor with a rotor shipping brace, then remove this before turning the rotor over or starting the machine up.
Make sure that the resting position of the roller bearings after the rotor has been turned over is different from what it previously had been. Use the fitted key or the coupling halves as reference markers.
- During re-commissioning, refer to the information in the "Commissioning" section.

See also

Commissioning (Page 63)

8.5.3 Measurement of the insulation resistance after an extended stoppage

Measuring the insulation resistance and polarization index (PI) provides information on the condition of the machine. It is therefore important to check the insulation resistance and the polarization index at the following times:

- Before starting up a machine for the first time
- After an extended period in storage or downtime
- Within the scope of maintenance work

The following information is provided regarding the state of the winding insulation:

- Is the winding head insulation conductively contaminated?
- Has the winding insulation absorbed moisture?

As such, you can determine whether the machine needs commissioning or any necessary measures such as cleaning and/or drying the winding:

- Can the machine be put into operation?
- Must the windings be cleaned or dried?

Detailed information on testing and the limit values can be found here:

"Testing the insulation resistance and polarization index" (Page 36)

8.6 Decommissioning the machine

NOTICE
Damage as a result of an extended period out of service
If the machine is going to be out of service for longer than six months, then take the necessary measures for preservation and storing. Otherwise damage to the machine will result.

Record the decommissioning steps. This log will be useful upon recommissioning.

See also

Transport and storage (Page 27)

8.7 Re-commissioning the machine

When you re-commission the machine, proceed as follows:

- Study the record made when the machine was decommissioned, and reverse the measures that were taken for conservation and storage.
- Perform the measures listed in the "Commissioning" section.

See also

Commissioning (Page 63)

8.8 Special operating conditions

Operating under light-load conditions

If a machine is operated continuously or over a long period under light-load conditions with approximately half rated current or less, damage will occur. High brush wear or problems with the commutator may result. More details are available in the chapter titled "Faults".

If the motor is to be operated continuously under light-load conditions, consult the manufacturer.

Loading at standstill

Load stationary DC motors with armature current only for short periods so as to protect the commutator against damage. Obtain the permissible current and time values for loading at standstill from the manufacturer.

8.9 Faults

8.9.1 Inspections in the event of faults

Natural disasters or unusual operating conditions, such as overloading or short circuit, are faults that overload the machine electrically or mechanically.

Immediately perform an inspection after such faults.

Correct the cause of the fault as described in the respective remedial measures section. Repair any damage to the machine.

8.9.2 Faults in operation

Table 8-2 Faults in operation

Symptoms of fault				
				General uneven running of machine
			↓	Vibrating brushes
			↓	High temperature rise (general)
			↓	Severe brush sparking
				Possible causes of faults
				Remedial measures
				Plant fault
X				Coupled motor out of balance Check coupling, rebalance system
X	X			Poor alignment Align motor set
X	X		X	Resonance in system Improve installation conditions or reduce excitation of vibration
				Operating mode or operating error
	X			Continuous light-load duty (partial load) Change number of brushes and/or material
		X		Temporary overload Correct current limit on converter
		X		Continuous overload Correct current limit on converter/reduce down periods of rest
				Cooling fault
		X		Cooling air-flow rate too low (commutator temperature too high) Improve ventilation circuit
				Component defect
			X	Interturn fault Repair winding
	X		X	Out-of-round commutator Rework commutator
X				Rotor imbalance Balance rotor
X				Bearing damage Repair or replace bearing

8.9.3 Faults at the external fan

The following table shows the possible causes of and remedial measures for faults on forced-ventilated machines.

Table 8-3 Cooling system faults

↓ High temperature rise with load		
	Possible causes of faults	Remedial measures
X	Wrong direction of rotation of the external fan	Check the electrical connections to the external fan.
X	External fan is not running	Check the external fan and its connections.
X	Reduced air flow	Check the air ducts; clean the machine.

8.9.4 Roller bearing faults

Note

Damage to roller bearings can be difficult to detect in some cases. If in doubt, replace the bearing. Use other bearing designs only **after consulting the manufacturer**.

Table 8-4 Roller bearing faults

↓ Bearing overheats			
		↓ Bearing "whistles"	
		↓ Bearing "knocks"	
		Possible causes of faults	Remedial measures
X		High coupling pressure	Align the machine more accurately.
X		Belt tension too high	Reduce the drive belt tension.
X		Bearing contaminated	Clean the bearing or replace it. Check the seals.
X		High ambient temperature	Use a suitable high-temperature grease.
X	X	Insufficient lubrication	Grease the bearings as instructed.
X	X	Bearing canted	Properly install the bearing.
X	X	Insufficient bearing play	Only after consultation with the manufacturer: Fit a bearing with greater play.
		X Excessive bearing play	Only after consultation with the manufacturer: Fit a bearing with lower play.
X	X	Bearing corroded	Replace the bearing. Check the seals.
X		Too much grease in bearing	Remove surplus grease.
X		Wrong grease in the bearing	Use the correct grease.
		X Friction marks on raceway	Replace the bearing.
		X Scoring (brinelling)	Replace the bearing. Avoid any vibration at standstill

8.9.5 Brush faults

Modify the arrangement of brush components or the brush material only with the manufacturer's agreement.

Table 8-5 Brush faults

Symptoms of fault				
				Knocked out or shattered brush edges
			↓	High degree of brush wear
			↓	High degree of wear despite good commutation
				Possible causes of faults
				Remedial measures
				Plant fault
		X		Coupled motor out of balance
		X		Check coupling, rebalance system
		X		Poor alignment
		X		Align motor set
		X		Mechanical jolts
		X		Improve installation conditions
				Cooling fault
X	X	X		Cooling air too dry
		X		Change brush material
	X	X		Silicone in the cooling air
		X		Remove silicone, clean machine and mounting parts
		X		Cooling air contains too much dust
		X		Change air ducting, use an air filter
		X		Cooling-air flow rate too low (commutator temperature too high)
		X		Improve cooling
				Brush fault
X	X			Incorrect or unsuitable brush material
				Change brush material
				Component defect
X	X			Out-of-round commutator
				Overrev commutator
X	X	X		Protruding segment insulation
		X		Pocket mill segment insulation
		X		Rotor imbalance
		X		Balance rotor

8.9.6 Commutator faults

Table 8-6 Commutator faults

Symptoms of fault						
↓					Beads of molten metal	
	↓				Generally severe bar blackening	
		↓			Some segments are blackened periodically	
			↓		Some segments are severely scorched	
				↓	Flat spots on commutator	
				↓	Grooves in circumferential direction	
					Possible causes of faults	
					Remedial measures	
					Plant fault	
		X			Poor alignment	Align motor set
			X		Mechanical jolts	Improve installation
					Operating mode or operating error	
				X	Continuous light-load duty (partial load)	Change number of brushes and/or material
			X		Temporary overload	Correct current limit
			X		Overload at standstill	Correct current limit/shorten standstill time
					Cooling fault	
	X				Cooling air too damp	Change air ducting
	X			X	Cooling air chemically aggressive	Change air ducting
				X	Cooling air contains too much dust	Change air ducting, use an air filter
				X	Cooling-air flow rate too high (commutator temperature too low)	Restrict air ducting (if necessary, change brush material)
					Brush fault	
			X		Incorrect or unsuitable brush material	Change brush material
	X				Brushes not in neutral zone	Correct setting
					Component defect	
			X		Interruption in armature winding	Repair winding
			X		Faulty solder joint	Resolder solder joint
		X		X	Out-of-round commutator	Rework commutator
X					Conductive inclusions in segment slots	Pocket mill segment insulation

Through careful and regular maintenance, inspections, and overhauls you can detect faults at an early stage and resolve them. This means that you can avoid consequential damage.



Operating conditions and characteristics can vary widely. For this reason, only general maintenance intervals can be specified here. Maintenance intervals should therefore be scheduled to suit the local conditions (dirt, starting frequency, load, etc.).

When carrying out any work on the machine, observe the general safety instructions (Page 15) and the specifications contained in EN 50110-1 regarding safe operation of electrical equipment.

Note**Service Center**

Please contact the Service Center (Page 137), if you require support with servicing, maintenance or repair.

9.1 Inspection and maintenance

 WARNING
Rotating and live parts Electric machines contain live and rotating parts. Fatal or serious injuries and substantial material damage can occur if maintenance work is performed on the machine when it is not stopped or not de-energized. <ul style="list-style-type: none">• Perform maintenance work on the machine only when it is stopped. The only operation permissible while the machine is rotating is regreasing the roller bearings.• When performing maintenance work, comply with the five safety rules (Page 15).
 WARNING
Machine damage If the machine is not maintained it can suffer damage. This can cause faults which can result in eventual or immediate death, serious injury or material damage. Perform regular maintenance on the machine.

 CAUTION
Dust disturbances when working with compressed air
When cleaning with compressed air, dust, metal chips, or cleaning agents can be whirled up. Injuries can result.
When cleaning using compressed air, make sure you use suitable extraction equipment and wear protective equipment (safety goggles, protective suit, etc.).

NOTICE
Damage to insulation
If metal swarf enters the winding head when cleaning with compressed air, this can damage the insulation. Clearance and creepage distances can be undershot. This may cause damage to the machine extending to total failure.
When cleaning with compressed air, ensure there is adequate extraction.

NOTICE
Machine damage caused by foreign bodies
Foreign bodies such as dirt, tools or loose components, such as screws etc., can be left by accident inside the machine after maintenance is performed. These can cause short circuits, reduce the performance of the cooling system or increase noise in operation. They can also damage the machine.
<ul style="list-style-type: none">• When carrying out maintenance work, make sure that no foreign bodies are left in or on the machine.• Securely attach all loose parts again once you have completed the maintenance procedures.• Carefully remove any dirt.

Note

Operating conditions and characteristics can vary widely. For this reason, only general intervals for inspection and maintenance measures can be specified here.

9.1.1 Initial inspection

- Perform the initial inspection after installing or commissioning the motor. Normally the initial inspection is only necessary after approx. 500 hours of operation.
- Perform follow-up inspections after every approx. 2,000 hours of operation.

**⚠ DANGER****Rotating or live parts**

Rotating or live parts are dangerous. Death, serious injury, or material damage can result if the required covers are removed.

Depending on the design, the motor may have inspection windows for monitoring the commutation behavior or covers. If there are no inspection windows, only qualified personnel is permitted to remove the covers. This ensures that there is no contact with live or moving parts. Wear safety goggles when working.

Checking the motor when in operation

The following must be checked during the first and any subsequent inspections:

- The relevant technical data are observed: power consumption, temperature of windings, bearings, coolants, etc.
- There should be no oil, grease, or water leakages.
- The smooth running characteristics and motor running noise have not deteriorated.
- No impermissible brush sparking occurs in operation.

Checking during idle time

Once the machine has been shut down, check that:

- The motor foundation has no indentations or cracks.
- The carbon brushes and commutators are in perfect condition. Commutator surfaces have an even finish.
- The brush holders are correctly aligned and mounted.
- Carbon brushes can move freely in the brush guides, and their pressure fingers can move freely in the articulated joints. The spring effect is consistent for all carbon brushes.
- There is sufficient brush height remaining to allow fault-free operation until the next inspection. The brush height must be reduced to below the minimum.
- Any defects discovered during checking should be fully corrected.

Note

The inspection measures may be required depending on the plant specification and operating conditions.

See also

Inspection at standstill (Page 146)

9.1.2 MTTR

Note

The operating conditions can vary greatly. For that reason, the following table only states general intervals for inspections and service during fault-free operation.

Table 9-1 MTTR in fault-free operation

Measure	Interval	Time limit
Initial inspection	After 500 operating hours	After a half year at the latest
Regreasing	After 1000 to 16 000 operating hours (depending on bearings and operating mode)	After three years at the latest
Cleaning	Dependent on local degree of pollution or when brushes are replaced	
Follow-up inspection	2,000 operating hours after the previous inspection	After a half year at the latest
General inspection	Approximately every 16 000 operating hours	After two years at the latest

9.1.3 Main inspection

The main inspection of the machine should be carried out after approximately 16000 operating hours, but no later than after two years of operation.



<p>! DANGER</p> <p>Rotating or live parts</p> <p>Rotating or live parts are dangerous. Death, serious injury, or material damage can result if the required covers are removed.</p> <p>If no inspection windows are fitted and, as a result, the appropriate covers need to be removed to allow inspection of the commutating performance, these covers may only be dismantled by specially qualified personnel. This ensures that there is no contact with live or moving parts. Wear safety goggles when working.</p>

Checking the motor when in operation

- The relevant technical data are observed: power consumption, temperature of windings, bearings, coolants, etc.
- There should be no oil, grease, or water leakages.
- The smooth running characteristics and motor running noise have not deteriorated.
- No impermissible brush sparking occurs in operation.

Checking during idle time

Once the machine has been shut down, check that:

- The motor foundation has no indentations or cracks.
- The carbon brushes and commutators are in perfect condition. Commutator surfaces have an even finish.
- The brush holders are correctly aligned and mounted.
- Carbon brushes can move freely in the brush guides, and their pressure fingers can move freely in the articulated joints. The spring effect is consistent for all carbon brushes.
- There is sufficient brush height remaining to allow fault-free operation until the next inspection date. The minimum brush height must be observed.
- The motor is aligned within the permissible tolerance range.
- All of the fixing screws for the mechanical and electrical connections are tight.
- The winding insulation resistances are sufficiently high.
- If the bearings are insulated, the insulation has not been bridged.
- Accessible cables and insulating parts are in good condition and are not discolored.

Any defects discovered during checking should be fully corrected.

Note

The inspection measures listed may be required depending on the plant specification and prevailing operating conditions.

9.1.4 Regreasing rolling-contact bearings

1. Clean the grease nipple.
2. Press in the type and quantity of grease specified on the lubricant plate in portions. The shaft must rotate so that the new grease is distributed throughout the bearing. The bearing temperature initially increases noticeably. After the excess grease has been displaced out of the bearing, the bearing temperature will fall to the normal value again.
3. Remove the outer bearing cover and remove the spent grease.
4. Then remount the bearing cover.
The space for the spent grease is designed for at least ten regreasing sessions.



WARNING

Possibility of the rotor falling out

The rotor can fall out when work is being carried out on the locating bearing and the motor is vertical. This can result in death, serious injury or material damage.

Support or relieve the rotor of any load when work is being carried out with the machine in a vertical position.

9.1.5 Regreasing intervals and grease types

Regreasing intervals

On machines with a regreasing device, the regreasing intervals are stated on the lubricant plate attached to the machine. Regrease the machine at the prescribed intervals.

Grease types

A grease rated for temperatures ranging down to -20 °C is normally used to initially lubricate rolling-contact bearings. The following high-quality greases for rolling-contact bearings are suitable and tested for temperatures down to -20 °C.

Table 9-2 Suitable greases for rolling-contact bearings (down to -20 °C)

K3N greases	K3K greases
ARAL / Aralub 4340	ARAL / Aralub HL 3
DEA / Glissando 30	BP / Energrease LS 3
ESSO / Beacon 3	ELF / Rolexa 3
ESSO / Unirex N3	MOBIL / Mobilux 3
FUCHS / Renolit FWA 220	
SHELL / Gadus S2 V100 3	
SHELL / Alvania R 3	
WINTERSHALL / Wiolub LFK 3	

These greases have lithium soap as the thickening agent and mineral oil as the base oil. They exceed the normal requirements of DIN 51825.

If you use other K3K or K3N greases, some of which only meet the minimum requirements per DIN 51825, halve the regreasing intervals. K3N greases have higher temperature reserves than K3K greases.

NOTICE

Damage from mixing lubrication types

If greases and oils with different soap or oil bases are mixed, their lubricating properties may no longer be assured.

Mixing low-temperature grease with normal temperature grease can cause lumps to form in the lubricant, and risk thermal damage to the rolling-contact bearing.

Never mix greases that have different thickening agents and different base oils.

Special types of grease are used on machines that are designed for use at temperatures below -20 °C. These grease types are specified on the lubricant plate. Other types of grease are not permitted.

9.1.6 Clean the machine

Cleaning the cooling air passages

- Regularly clean the cooling air ducts through which the ambient air flows. The frequency of the cleaning intervals depends on the degree of pollution.
- In addition, every time a worn brush set is replaced, clean the internal cooling air ducts (where accessible) and the insulating components of the commutator and the brush holder.

Removing brush dust

- Remove all deposits of brush dust on insulating components, e.g. using a brush and suitable extraction equipment.
- Disassemble motors with enclosed internal looped circulation and no fine dust filter, once three brush sets have been eroded. Thoroughly remove all brush dust from the motor.
- When brush rockers are cleaned, care must be taken not to damage the trip mechanism on motors with brush-height monitoring.
- Replace the dirty filter mats. Alternatively, remove the filter mat and wash it. Reinstall the filter mat unwetted after drying.

Note

Damage on the surface of the sound absorber elements

On external fans with sound absorbers, the surface of the absorber elements is pressure-sensitive. Air-pressure cleaning can damage this surface.

- Air-pressure cleaning equipment should not be used directly on the sound absorber elements.
 - Carefully brush away any large deposits of dust which could be drawn in whole by the air flow.
-

- After cleaning, check the insulation resistance (Page 36).

9.1.7 Checking the carbon brushes

In normal operation, check regularly to ensure the carbon brushes are in good contact with the commutator and are moving freely in the brush guides.

Brush height

The wear limit of carbon brushes is indicated by a line or by the lower edge of the manufacturer's name stamp.

On machines with a brush-height monitoring function, the shortest brush opens a microswitch when the brush has worn to at least 2 mm higher than the minimum brush height. Under normal operating conditions, the machine can then continue to operate for a further 500 to 1,000 hours.

NOTICE

Worn carbon brushes

If the motor is operated with worn carbon brushes, this can lead to material damage.

Replace used carbon brushes immediately.

9.1.8 Replacing the carbon brushes

Removing worn carbon brushes

All brush holders can usually be accessed by opening the cover/louvered cover on the bearing shield at the non-drive end.

1. Disconnect the cables from the brush rocker if necessary.
2. After you have loosened the lock screws accessible from the inside, turn the brush rocker into an easily accessible position.



CAUTION

Open pressure levers can spring back

Open pressure levers on brush holders can spring back, causing minor injuries. When working on a brush holder, make sure that the holder finger does not snap shut.

Mounting new carbon brushes

1. When you replace carbon brushes, make sure that you replace them with exactly the same type and model.
You will find the brush type and manufacturer's mark on the upper part of carbon brushes.
2. Prepare a strip of emery cloth that is not too coarse. The following dimensions are required: width equal to the commutator contact length and length equal to the commutator circumference.
3. Fix the strip of emery cloth to the commutator using double-sided adhesive tape.
4. Insert the new carbon brushes.
5. Manually, slowly turn the commutator in the correct direction of rotation. In exceptional cases, pull the emery cloth through under the brushes by hand until the entire brush surface is resting in contact with the commutator.
Avoid damaging the brush edges when grinding in the new carbon brushes.
6. Carefully remove the emery cloth and any adhesive-tape residue left behind on the commutator surface.

7. Thoroughly suck (or blow) out the brush dust which has settled.
8. Check that all brush holders are correctly closed.

9.1.9 Setting the brush rocker and brush holder

1. After you have replaced the carbon brushes, make sure that you adjust the brush rocker exactly.
You will find a line on the bearing shield and on the brush rocker itself for this purpose. The rocker is positioned correctly when both marks are lined up. The marking can be viewed from one of the service openings.
2. Bolt the brush rocker.

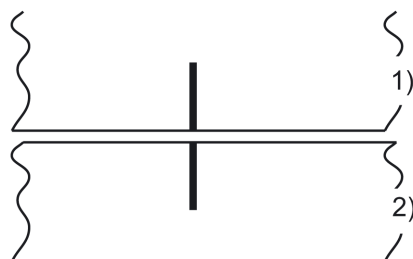

Image 9-1 Adjusting the brush rocker: fixed part (1), brush rocker (2)

Adjusting the brush holders

1. Check the radial clearance between the commutator and the lower edge of the brush holder. The setting clearance is steplessly adjustable and between 1.5 and 2 mm. The brush holder can be set inside the machine.

9.1.10 Maintaining the commutator

Cleaning the commutator

- To remove oil, grease and/or dust, clean the commutator with a non-linting cloth .
- Clean the slots between the commutator segments with a suitable wooden slat or glass pencil.

Note

Sparking or flashover caused by unclean slots

Dirty slots can cause sparking or flashovers on the commutator.

Reworking the commutator after the formation of grooves

Moderate scoring or burn marks do not affect the operational reliability of the machine. The commutator only needs to be overhauled if it is seriously scorched or grooved and/or is out-of-round.

- Grind the commutator in the mounted position with a commutator grinder of medium grain size, grain number 80 (210 - 177 μm).
- To do this, lift most of the brushes and operate the motor at a speed of approximately 600 rpm.
- Place the grinder on the brush holder.

Note

Suck or blow the dust out

Dust inside the motor can cause winding damage. Suck or blow the dust out.

- Remove the grinding dust with dry, oil-free compressed air. Deburr the edges of the segments if necessary.
- Where the commutator is severely out-of-round, remove the rotor and skim the commutator on a turning machine. You can skim the commutator down to the smallest permissible diameter (d_{min}) given in the following table.

Table 9-3 Commutator overhaul – minimum permissible diameter

Shaft height	Nominal diameter d_N (mm)	Minimum diameter d_{min} (mm)
1G.5 / 1H.5		
500	560	546
630	720	706
1G.6 / 1H.6		
160	160	154
180	190	184
200	210	202
225	240	232
250	265	257
280	300	292
1G.7 / 1H.7		
355	350	340
400	350	340
450	400	390

Reworking the slots

- If the commutator is skimmed, the slots should also be remachined, e.g. with a special saw. The following diagrams give the recommended slot dimensions.

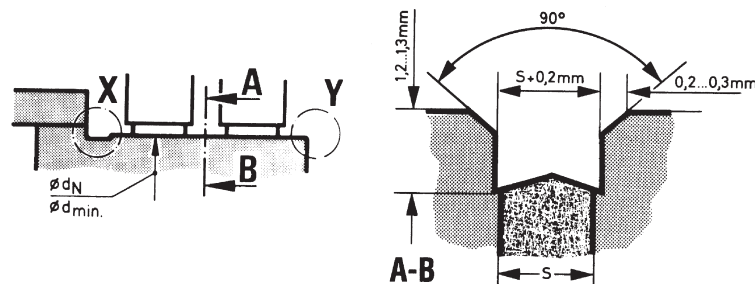

Image 9-2 Reworking the slots

- Depending on the method used to machine the slots, it is useful to machine an undercut as shown in the diagram below (detail X) when the commutator is skimmed. This undercut must not be deeper than 1 mm for the smallest permissible commutator diameter.

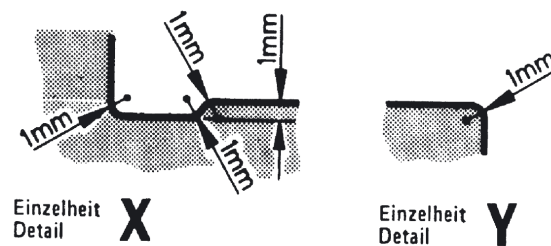

Image 9-3 Final work on the commutator after skimming.

Final measures

- After the commutator has been reworked, adjust the brush rocker and the brush holder (Page 91).

9.1.11 Maintaining terminal boxes

Requirement

The machine is de-energized.

Checking for tightness

- Terminal boxes must be regularly checked for tightness, undamaged insulation, and tight terminal connections.
- If dust or humidity have infiltrated the terminal box, this should be cleaned and dried (particularly the insulators).

- Check the seals and sealing surfaces. Rectify the cause of the leak.
- Check the insulators, connectors and cable connections in the terminal box.
- Replace the damaged components if necessary.

 WARNING
Short-circuit hazard
Short circuits, for example, can occur as a result of damaged components. This can result in death, serious injury or material damage.
Replace damaged components.

Checking after subsection to heavy current

If the terminal box or the motor has been subjected to extremely heavy current, inspect the electrical components.

9.1.12 Touch up any damaged paintwork

If the paint is damaged, it must be repaired in order to protect the unit against corrosion.

Note

Paint system

Contact the Service Center (Page 137) before you repair any paint damage. They will provide you with more information about the correct paint system and methods of repairing paint damage.

9.2 Repair

When carrying out any work on the machine, observe the general safety instructions (Page 15) and the specifications contained in EN 50110-1 regarding safe operation of electrical equipment.

Note

If the motor has to be transported, please observe the information and instructions in the "Transport" (Page 27) section.

9.2.1 Prepare servicing work

- The drawings and parts lists do not contain any detailed information about the type and dimensions of fixing elements and components. For this reason, you should establish this information when dismantling them and make a note of it for the purpose of reassembly.
- Document the type, dimensions and arrangement of the parts so that you will be able to reassemble the machine to its original state.
- Use suitable tools to disassemble the machine.
- Take measures to prevent parts from dropping down before you dismantle them, e.g. by replacing fastening elements with extra-long screws, threaded bolts or similar. This ensures that the part is supported after it is pulled off.
- The centerings in the shaft extensions have reset threads. Use lifting gear which is suitable for the rotor weight and direction of loading.

 **WARNING**

Rotor can fall down

Eyebolts in accordance with DIN 580 are unsuitable for suspending the rotor. The rotor can fall off. This can result in death, serious injury or material damage.

Use lifting gear which is suitable for the rotor weight and direction of loading.

 **WARNING**

Machine damage caused by improper repair work

Improper servicing work can damage the machine. This can cause damages and/or faults which can result in eventual or immediate death, serious injury, or property damage.

- Properly assemble or disassemble the machine.
- Use only suitable tools and equipment.
- Immediately replace damaged components.
- Contact the Service Center (Page 137), if necessary.

 **WARNING**

Rotor can fall out

If the motor is in a vertical position, the rotor can fall out while work is being performed on the locating bearing. This can result in death, serious injury or damage.

- Support or unload the rotor when carrying out work with the machine in a vertical position.

Removing the machine

Note

Only qualified personnel is permitted to perform maintenance work. Contact the Service Center (Page 137), if necessary.

- If you have to disassemble the motor, disconnect the connecting leads from the terminals and the entry plate from the terminal box casing. In this way, the relative positions of the cables will remain correct. Effective sealing of the cables in the cable entries is retained.
- Check the identification of the connecting cables. If the identifiers are not correct, correct the identification.

Wiring

The terminal diagram shows only the mains connection conditions without including any compensation and auxiliary windings.

Mark internal connections for identification before disconnecting them for maintenance work.

9.2.2 Disassembling the machine

Attaching a rotor

The centerings in the shaft extensions have reset threads. Eyebolts conforming to DIN 580 are not suitable for vertical rotor attachment as only a small number of thread grooves are used.

- Depending on the weight of the rotor and the direction of the load, other suitable elements (with a length of engagement $> 0.8 \times$ thread diameter) should be used.

Disassembling the machine

1. The drawings and parts lists do not contain any detailed information about the type and dimensions of fixing elements. Therefore, make sure their assignment is correct before disassembly. Mark their assignment with identification for assembly.
2. Before disassembly, ensure that the housing and bearing shield are marked at a corresponding point on the non-drive end. Use a suitable means of identification, e.g. a flat chipping mark. The correct position of the brush rocker in relation to the bearing shield and stator frame is important for setting the neutral zone.
3. Ensure correct assignment and orientation of the parts: bearings, sealing rings, compression springs, spring washers, covers with different centering lengths.
4. When removing the DE bearing shield, make sure that the windings that project from the stator frame do not become damaged.

5. Before pulling off any parts that have been screwed on, replace two of the fixing screws at the top with excessively long screws or threaded bolts. This ensures that the part is supported after it is pulled off.
6. Use forcing-off bolts or suitable devices to disassemble parts and components attached to the motor shaft.

9.2.3 Removing rolling-contact bearings

- When removing rolling-contact bearings, ensure the parts are correctly allocated if they are the same size at the drive end and non-drive end. This affects the bearings, compression springs, equalizing rings, and covers with different centering lengths.
- Label the components as they are removed so that they can be correctly allocated during assembly.

9.2.4 Installing the machine

- If possible, assemble the motor on an aligning plate. This ensures that the brush rocker is positioned correctly relative to the stator frame and the footings lie on a plane.
- When mounting the DE bearing shield, ensure that the windings that project from the stator housing do not become damaged.

Sealing the motor

- Clean bare joints between parts, e.g. between enclosures, end shields and the active parts of bearings.
- Grease the uncoated joints.
- For more stringent degree of protection requirements, a joint sealant is often used. In this case, also seal the joints with a suitable silicone-free, non-setting sealing compound during assembly. Use the sealing compound when inserting the relevant fixing screws.
- Check the installed sealing elements. If the sealing elements do not seal sufficiently, replace them.

Bolt locking elements

- Refit nuts or bolts that are mounted together with locking, resilient, and/or force-distributing elements with identical, fully-functional elements when re-assembling. The force distributing element include, for example, lock washers, split rings, etc.
- Always replace keyed safety elements.
- Always mount the fixing screws with a clamping length < 25 mm during assembly using suitable locking elements or a soluble threadlocker. For example, use split rings, spring washers, or LOCTITE. The clamping length is taken as the distance between the head of the bolt and the point at which the bolt is screwed in.

9.2.5 Mounting the rolling-contact bearings

Take great care and pay attention to cleanliness when fitting and assembling the bearings.

Make sure that you use the correct components for the rolling-contact bearing type in question. For information about the rolling-contact bearings installed, please refer to the lubricant plate.

Mounting the rolling-contact bearings

1. Heat the ball bearings or cylindrical-roller bearing's inner rings in oil or air at a temperature of 100 °C.
2. Then push the ball bearings or the inner rings onto the shaft at the inner ring of the bearing, up to its shoulder. Avoid any heavy blows that might damage the bearing.
3. Fill the bearing to the top with the specified lubricating grease (Page 88).
4. Check that the existing sealing rings still perform their function. Replace the sealing rings if necessary.

Sealing the bearings

- Before installing new felt rings in the bearing cover, soak them in hot, highly viscous oil at approximately 100 °C, such as DIN 51517-C100 lubricating oil. They must be dimensioned such that the shaft can move freely, but is tightly enclosed by the rings.
- When installing external V-rings, the V-ring has reached the correct axial position when the end face of the bearing cover is flush with the outer edge of the V-ring. Use an appropriate auxiliary installation disk for this purpose.
- Check whether an additional sheet-metal protecting ring has been inserted in the bearing cover or bearing shield to protect the V-Ring. If so, pay attention to the following points during assembly:
 - The ring has sufficient pretension.
 - One of its two slots coincides with the corresponding water drainage slot provided at the bottom of the bearing cover seat or bearing shield seat.
- If rotary shaft seals without helical springs are installed, also install the replacement part without a spring.

Speed sensor

- If you are using a speed sensor with an inner V-ring on the outer bearing cover, the V-ring must be positioned against the shoulder of the shaft journal.

9.2.6 Replacing the speed encoder

9.2.6.1 Speed sensor with conical hub

Disassembly

The speed-sensor rotor with its conical hub either rests on, or is bolted to, the machine shaft journal.

Note

Damage to the speed sensor

The speed sensor can be damaged during motor disassembly. Remove the speed sensor before disassembling the motor.

1. Remove the cover of the speed sensor.
2. Unscrew the speed-sensor stator and move it away, axially. Take care with the brushes when doing this.
3. Unscrew the central M6 fixing screw from the speed-sensor rotor.
4. Insert a steel pin (4.8 x 24) into the threaded hole to support the forcing-off bolt.
5. Screw the M8 forcing-off bolt (minimum thread length 30 mm) into the threaded hole of the hub of the speed-sensor rotor, thus forcing the rotor off the conical base of the shaft journal.
6. The shaft journals or half-couplings mounted on or in the machine shaft extension must be dismantled and replaced if they are damaged.
 - When replacing damaged parts, such as the tolerance ring, please ensure they are correctly arranged.
 - Use removable LOCTITE and suitable tools to assemble parts.
7. Use a socket screw wrench to DIN 3113 (width between pivots 35 mm) to screw or unscrew the bolt-mounted shaft journal.

Table 9-4 Recommended torques for tightening the shaft journal

Thread size	Torque [Nm]
M16	20
M20	30
M24	40

Assembly

Reinstall the disassembled speed sensor and secure it in position.

The legend numbers in the following illustration are explained in chapter Spare parts / Speed sensor (Page 129).

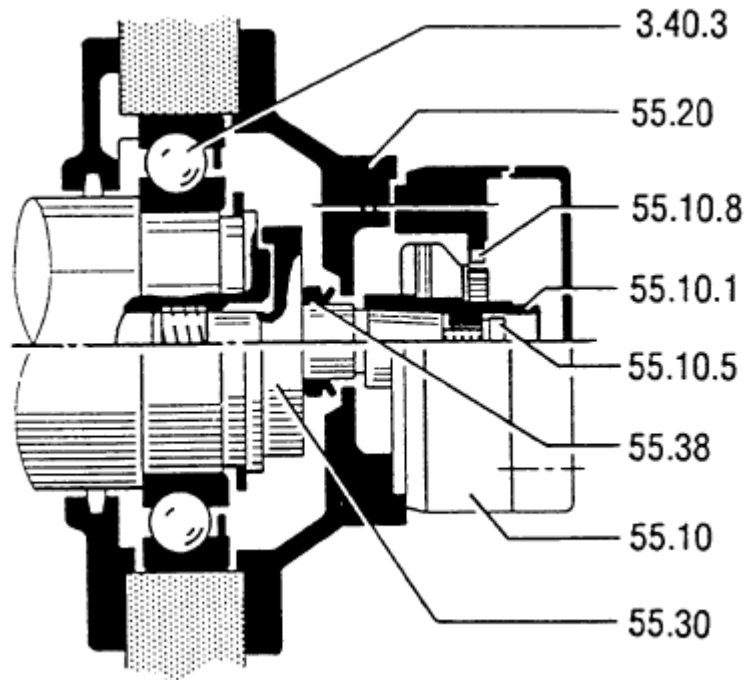

Image 9-4 Speed sensor assembly

1. Place the speed-sensor rotor on the conical shaft journal and tighten it to a torque of 10 Nm using one M6 screw.
2. Test the rotor to see if it is running smoothly. The permissible rotor deviation on the commutator is 0.05 mm.
3. Mount the speed-sensor stator. Ensure that the brushes still have sufficient length and do not become damaged.

9.2.6.2 Speed sensor for overhung mounting

Disassembly

With speed sensors for overhung mounting, the speed-sensor rotor is bolted to the machine shaft journal or inserted cylindrically.

Note

Damage to the speed sensor

The speed sensor can be damaged during motor disassembly. Remove the speed sensor before disassembling the motor.

1. Unscrew the speed-sensor stator and move it away, axially.
2. Remove the speed-sensor rotor. To do this, release the lateral set screw in the shaft journal and pull the rotor out, axially.

3. The shaft journals or half-couplings mounted on or in the machine shaft extension must be dismantled and replaced if they are damaged.
 - When replacing damaged parts, such as the tolerance ring, please ensure they are correctly arranged.
 - Use removable LOCTITE and suitable tools to assemble parts.
4. Use a socket screw wrench to DIN 3113 (width between pivots 35 mm) to screw or unscrew the bolt-mounted shaft journal.

Table 9-5 Recommended torques for tightening the shaft journal

Thread size	Torque [Nm]
M16	20
M20	30
M24	40

Assembly

Reinstall the disassembled speed sensor and secure it in position.

The legend numbers in the following illustration are explained in chapter Spare parts / Speed sensor (Page 129).

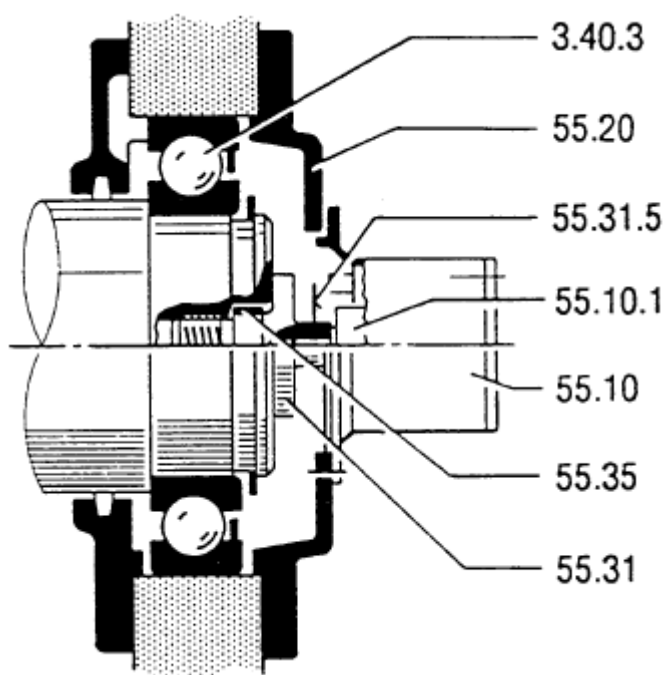

Image 9-5 Speed sensor assembly

- Push the cylindrical shaft extension of the speed-sensor rotor as far as possible into the shaft journal and secure it with the lateral set screw (M4 x 6).
- Use removable LOCTITE and a tightening torque of 13 Nm to attach the set screw.

- Test the rotor to see if it is running smoothly. The permissible rotor deviation on the commutator is 0.2 mm.
- Mount the entire speed-sensor stator.

9.2.6.3 Speed sensor for construction type IM B5

Removal

The speed encoder is designed for mounting, corresponding to type of construction IM B5. It is driven through a jaw clutch (Rotex).

If a different design is used, the installation and operating instructions of the speed encoder manufacturer apply.

Note

Damage to the speed encoder

The speed encoder can be damaged when removing the machine. Remove the speed encoder before removing the motor.

1. Completely unscrew the speed encoder and move it away, axially. This separates the coupling halves axially.
2. The shaft journals or half-couplings mounted on or in the machine shaft extension must be removed and replaced if they are damaged.
 - When replacing damaged parts, such as the tolerance ring, please ensure they are correctly arranged.
 - Use LOCTITE that can be removed and suitable tools to assemble parts.
3. Release or tighten the screwed-in coupling part at the hexagon socket head screw (Allen screw, 8mm)

Table 9-6 Recommended torques for tightening the coupling

Thread size	Torque [Nm]
M16	20
M20	30
M24	40

Installation

Firmly reattach the speed encoder that was removed. If a different design is used, the installation and operating instructions of the speed encoder manufacturer apply.

The legend numbers in the following illustration are explained in chapter Spare parts / Speed encoder (Page 129).

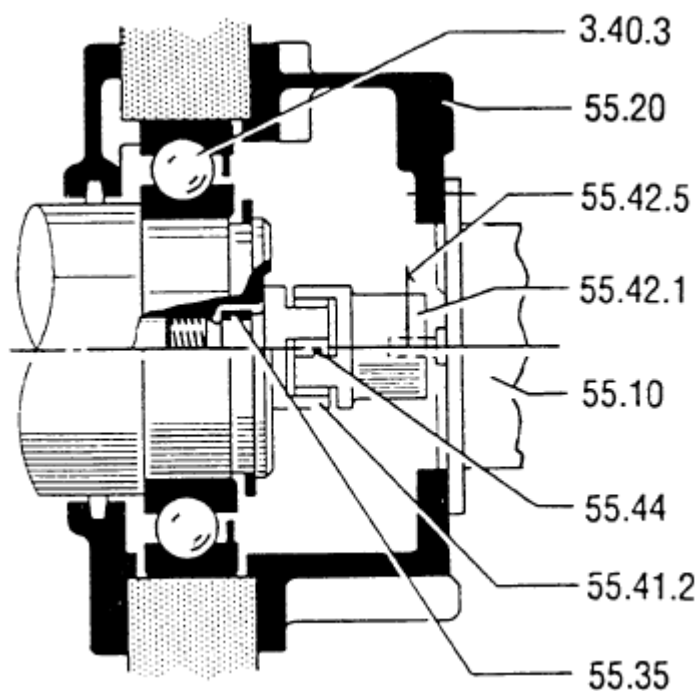

Image 9-6 Speed encoder mounting

1. If the coupling at the speed encoder end has been separated, use removable LOCTITE to secure the lateral stud bolt or set screw when the coupling is assembled and tighten with the correct torques.

Table 9-7 Tightening torques for mounting couplings

Thread size	Tightening torque [Nm]
M4	1.3
M5	2.6
M6	4.5

1. Check the elastic connecting link (coupling star) to ensure that it is in a good condition and in the correct mounting position.
2. Mount the complete speed encoder.

Spare Parts

10.1 Ordering data

In addition to the exact part designation, please specify the machine type and serial number in all orders for spare parts. Ensure that the spare part designation matches that on the spare parts list and make sure you use the appropriate part number as well.

Example

- Bearing shield, drive end (Part 5.00)
- Machine type
- Serial number

The machine type and serial number can be found on the rating plate. The serial number is also stamped on the end face of the shaft extension at the drive end.

Note

The graphical representations in this chapter show schematic diagrams of the basic versions. They are used for spare parts definitions. The supplied version may differ in details from these representations.

Carbon brushes

The order number for carbon brushes and / or the brush designation is specified on the rating plate. You will also find the brush type and manufacturer's mark on the upper part of the brush.

Terminal box

If several terminal boxes are mounted on the machine, please also indicate the type designation of the terminal box in addition to details of part designation and part number according to the legend, as well as type and serial number of the motor when ordering spare parts.

Example

- Terminal box type
- Terminal box cover (part 20.30)
- Serial number of the motor
- Machine type

Rolling-contact bearings

When ordering roller bearings, in addition to the bearing identification code, the supplementary specifying code is also necessary for the bearing version. Both of these codes are stamped on the lubricant plate and specified in the motor documentation, or can also be taken from the installed bearings.

If roller-contact bearings with an insulated design are installed, use roller bearings of the same type as spare parts. This will prevent any bearing damage being caused by bearing currents.

10.2 Ordering spare parts via the Internet

Spare parts can be ordered online from the spare parts service "Spares on Web":

Spares on Web (https://b2b-extern.automation.siemens.com/spares_on_web).



You can use "Spares on Web" to determine the order numbers for motor spare parts quickly and easily.

A short description of how to use "Spares on Web" is available on the Internet.

Guide for Spares on Web (<http://support.automation.siemens.com/WW/news/en/25248626>).

10.3 Using commercially available spare parts

You can use commercially available, standard components, but ensure that they have the same construction type, dimensions, strength class etc.

10.4 Stator and rotor, shaft height 160

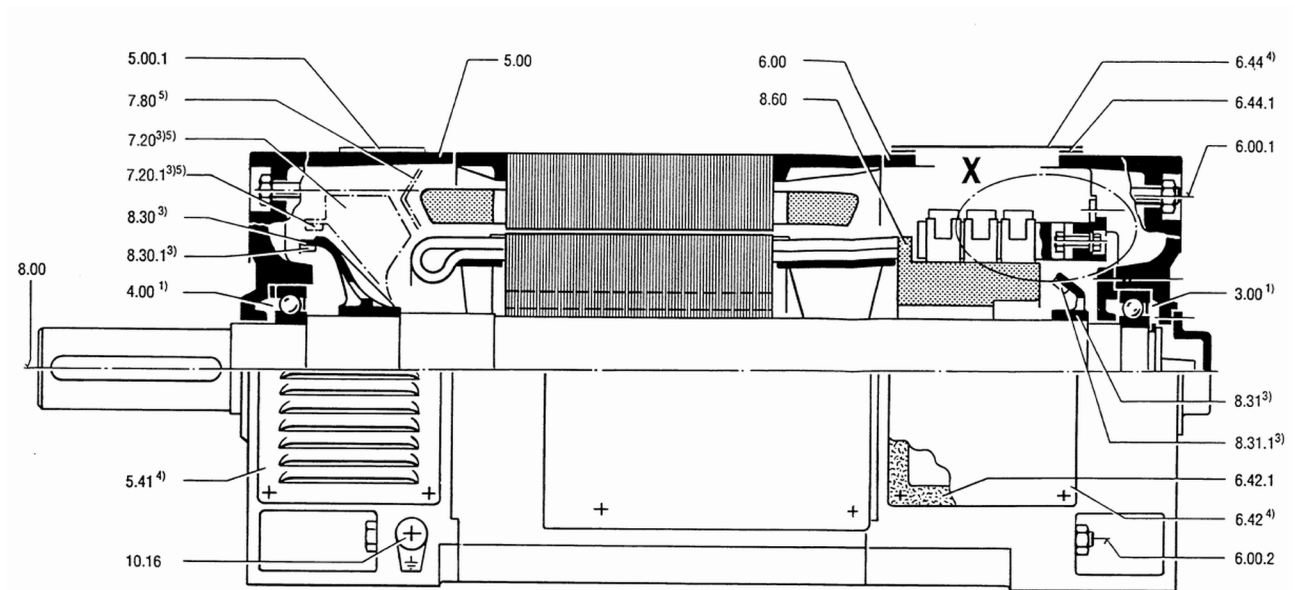

Image 10-1 Side view 1G.6 shaft height 160

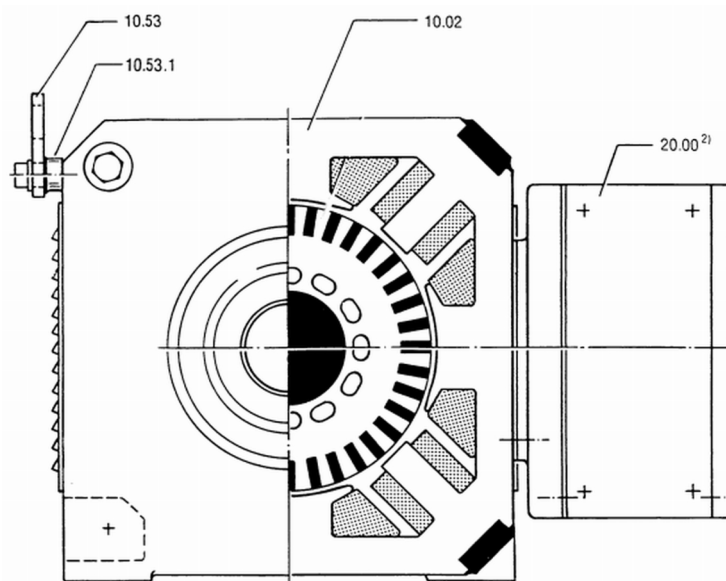

Image 10-2 Front view 1G.6 with shaft height 160

10.4 Stator and rotor, shaft height 160

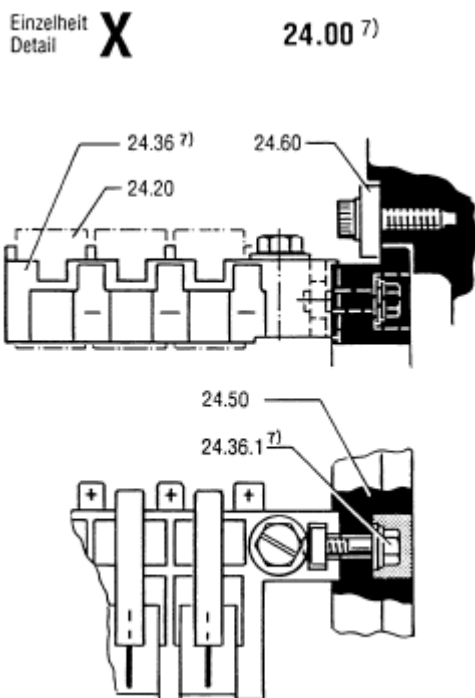

Image 10-3 Detail X brush holder 1G.6 shaft height 160

Table 10-1 Spare parts stator and rotor 1G.6, shaft height 160

No.	Designation	No.	Designation
3.00	Rolling-contact bearing unit, locating bearing, non-drive end	8.30	Air guide wheel, drive end
4.00	Rolling-contact bearing unit, floating bearing, drive end	8.30.1	Tare set
5.00	Bearing shield, drive end	8.31	Balancing ring, non-drive end
5.00.1	Rating plate	8.31.1	Tare set
5.41	Louvered cover	8.60	Commutator
6.00	Bearing shield, non-drive end	10.02	Stator frame complete with main and commutating coil resistors
6.00.1	Set screw	10.16	Grounding connection
6.00.2	Set screw	10.53	Special lifting eye
6.42	Side cover	10.53.1	Sleeve
6.42.1	Seal	20.00	Terminal box
6.44	Top cover	24.00	Brushgear unit, complete
6.44.1	Seal	24.20	Carbon brushes
7.20	Fan impeller, drive end	24.36	Multiple pocket brush holder
7.20.1	Tare set	24.36.1	Fastening screw
7.80	Air baffle plate	24.50	Brush holder (brush rocker, complete)
8.00	Rotor, complete	24.60	Single-acting clamping shoes (clamp straps) for brush holder

10.5 Stator and rotor, shaft heights 180 to 280

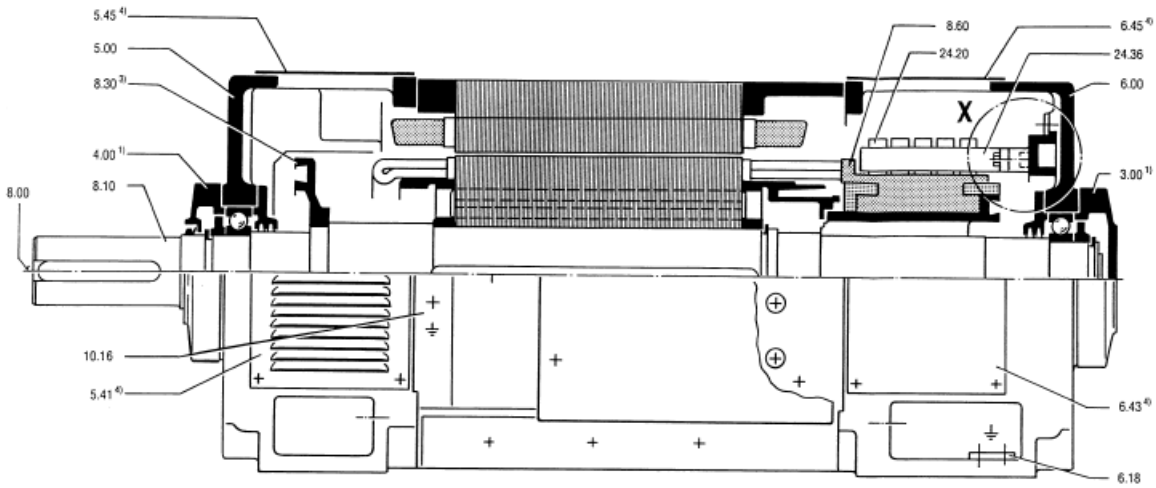

Image 10-4 Side view 1G.6, 1H.6 shaft heights 180 to 200

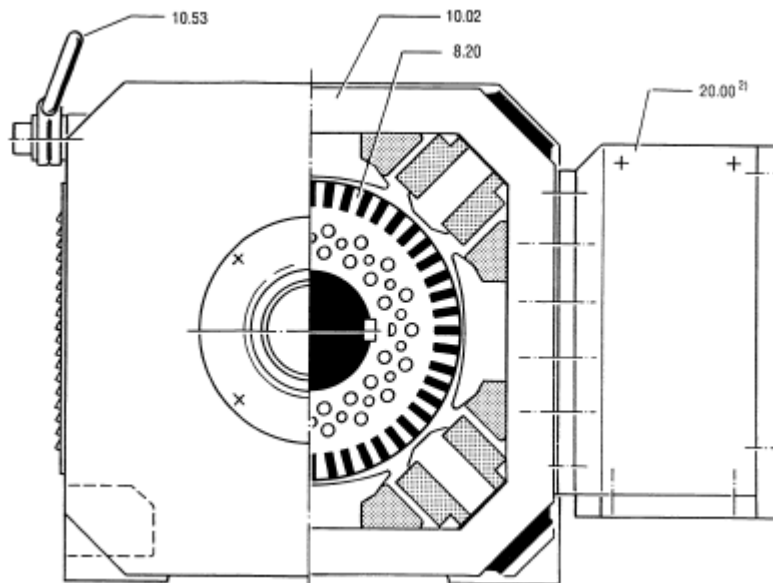

Image 10-5 Front view 1G.6, 1H.6 shaft heights 180 to 200

Spare Parts

10.5 Stator and rotor, shaft heights 180 to 280

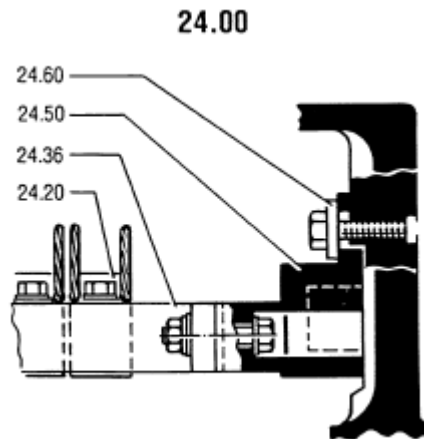

Image 10-6 Detail X brush holder 1G.6, 1H.6 shaft heights 180 to 200

Table 10-2 Spare parts stator and rotor 1G.6, 1H.6, shaft heights 180 to 200

No.	Designation	No.	Designation
3.00	Rolling-contact bearing bush (locating bearing)	8.60	Commutator
4.00	Rolling-contact bearing bush (floating bearing)	10.02	Stator frame with main and commutating coil resistors
5.00	Bearing shield, drive end	10.16	Grounding connection
5.41	Louvered cover	10.53	Special lifting eye
5.45	Cover with seal	20.00	Terminal box
6.00	Bearing shield, non-drive end	24.00	Brushgear unit, complete
6.18	Fixing lug for grounding	24.20	Carbon brushes
6.43	Cover with seal	24.36	Multiple pocket brush holder
6.45	Cover with seal	24.50	Brush holder (brush rocker, complete)
8.00	Rotor, complete	24.60	Single-acting clamping shoes (clamp straps) for brush holder

10.6 External fan

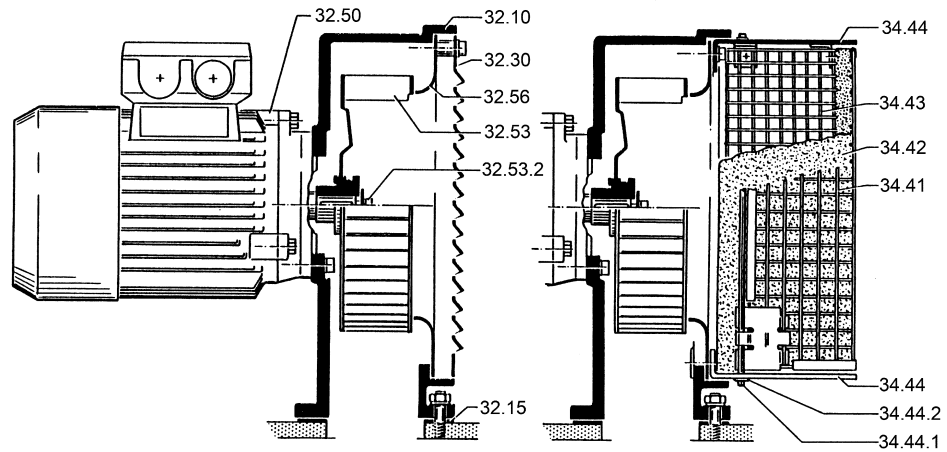

Image 10-7 External fan 1GG6

Table 10-3 Spare parts external fan 1GG6

No.	Designation	No.	Designation
32.10	Housing	34.41	External grille cover
32.15	Seal	34.42	Filter mat
32.30	Louvered cover	34.43	Inside basket
32.50	Fan motor	34.44	Border (two-part)
32.53	Fan impeller	34.44.1	Pin
32.53.2	Washer	34.44.2	Lockwasher
32.56	Air nozzle		

10.7 Rolling-contact bearing

10.7.1 Rolling-contact bearing for 1G.6, 1H.6, shaft height 160 without regreasing device, drive end

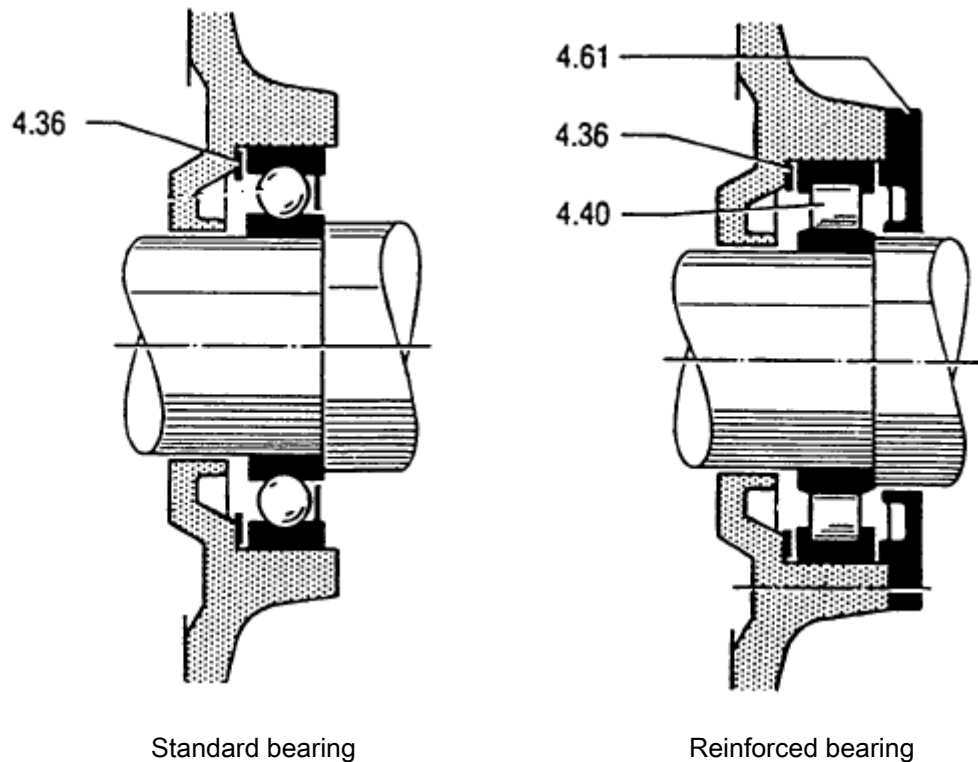
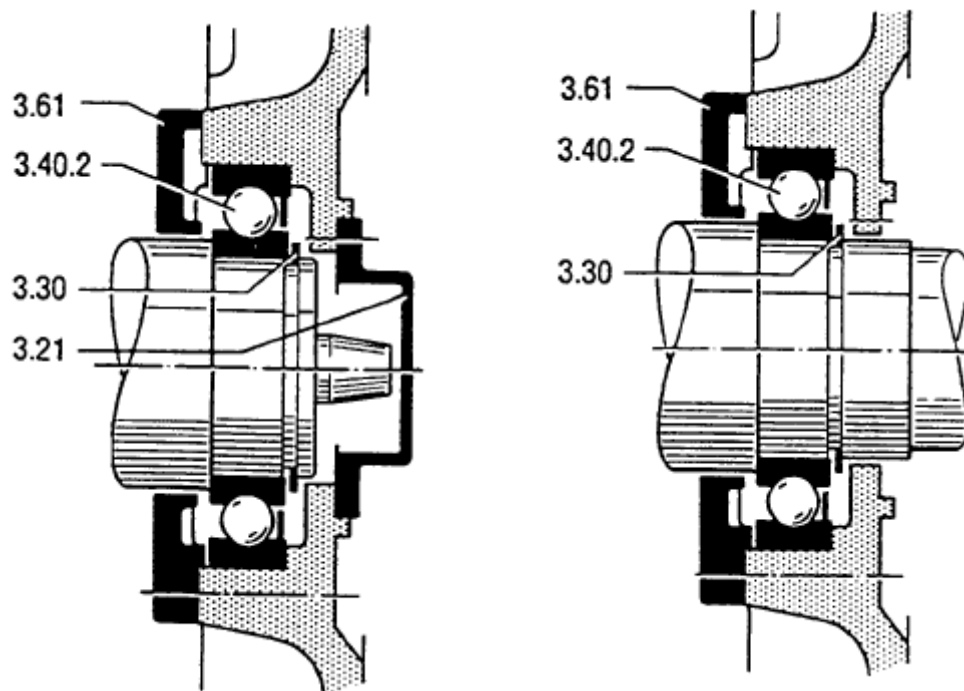

Table 10-4 Spare parts rolling-contact bearing for 1G.6, 1H.6, shaft height 160 without regreasing device

No.	Designation
4.36	Outer bearing cover
4.40	Inner bearing cover with felt rings
4.61	Deep-groove ball bearing (deep-groove ball bearing with sideplate, locating bearing)

10.7.2 Rolling-contact bearing for 1G.6, 1H.6, shaft height 160 without regreasing device, non-drive end



Locating bearing with one shaft extension

Locating bearing with two shaft extensions

Table 10-5 Spare parts rolling-contact bearing for 1G.6, 1H.6, shaft height 160 without regreasing device

No.	Designation
3.21	Outer bearing cover
3.30	Locking ring
3.40.2	Deep-groove ball bearing
3.61	Inner bearing cover with felt rings

10.7.3 Rolling-contact bearing for 1G.6, 1H.6, shaft height 160 with regreasing device, drive end

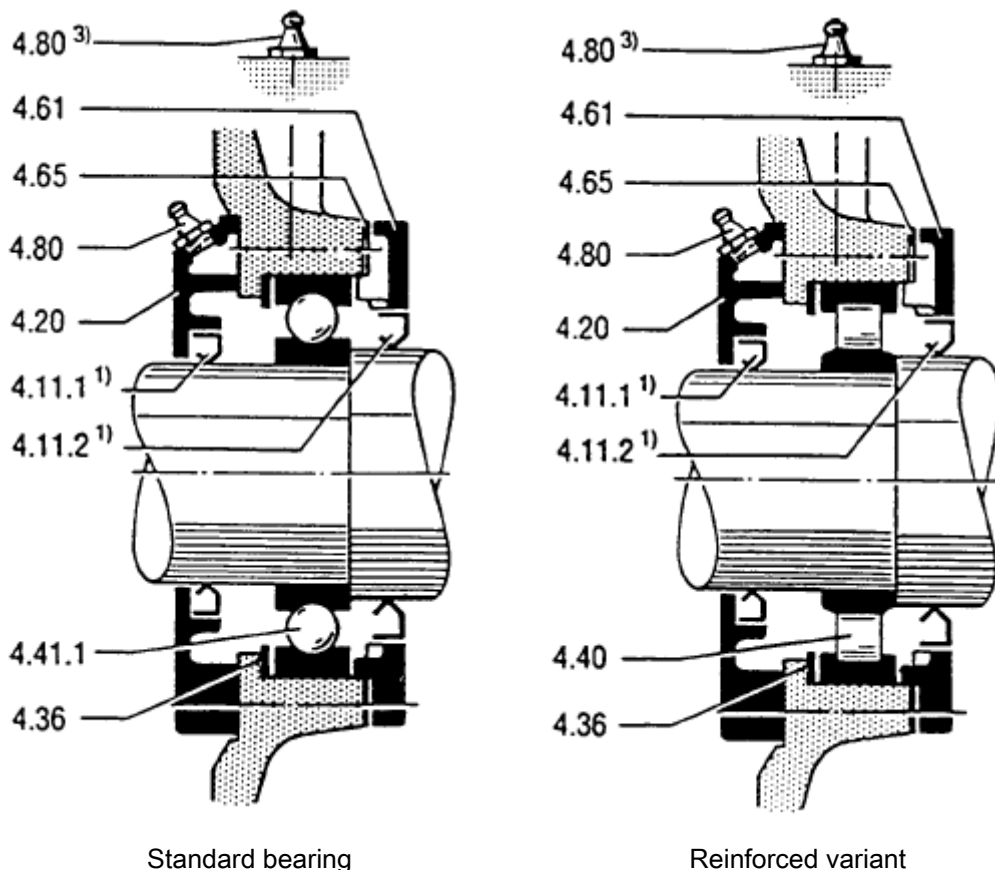
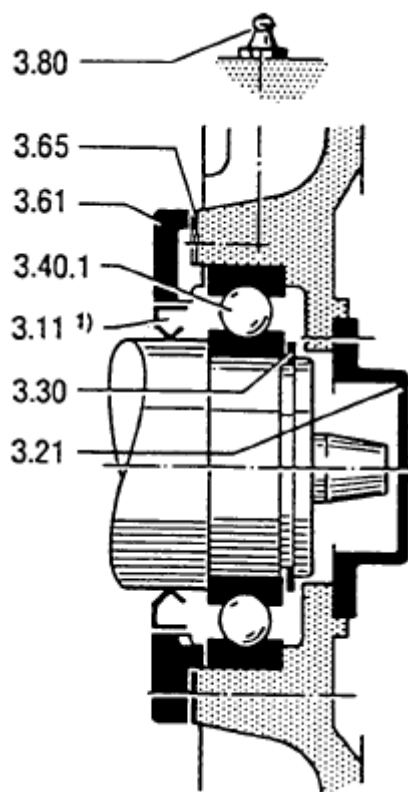

Table 10-6 Spare parts rolling-contact bearing for 1G.6, 1H.6, shaft height 160 with regreasing device

No.	Designation	No.	Designation
4.11.1	Radial shaft sealing ring outer	4.41.1	Deep-groove ball bearing as floating bearing
4.11.2	Radial shaft sealing ring inner	4.61	Inner bearing cover
4.20	Outer bearing cover	4.65	Seal
4.36	Pressure disk	4.80	Grease nipple
4.40	Cylindrical-roller bearing		

10.7.4 Rolling-contact bearing for 1G.6, 1H.6, shaft height 160 with regreasing device, non-drive end



Locating bearing with one shaft extension

Table 10-7 Spare parts rolling-contact bearing for 1G.6, 1H.6, shaft height 160 with regreasing device

No.	Designation	No.	Designation
3.11	Radial shaft sealing ring	3.61	Inner bearing cover with felt rings
3.21	Outer bearing cover	3.65	Seal
3.30	Locking ring	3.80	Grease nipple
3.40.1	Deep-groove ball bearing		

10.7.5 Rolling-contact bearing for 1G.6, 1H.6, shaft heights 180 to 200 without regreasing device, drive end

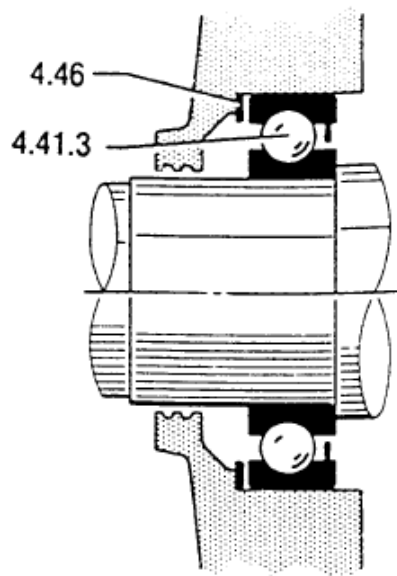

Standard bearing

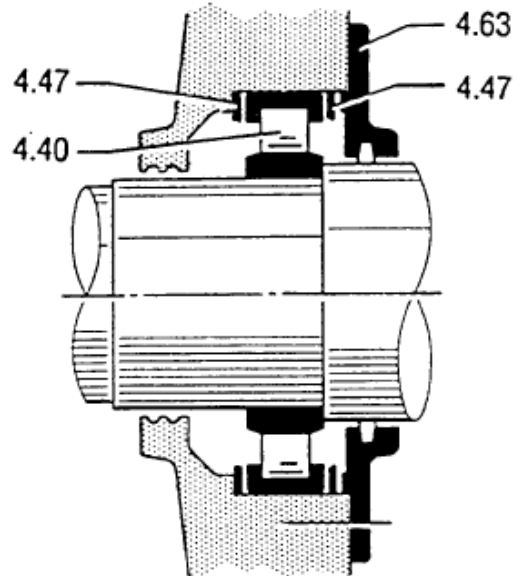

Reinforced bearing

Table 10-8 Spare parts rolling-contact bearing for 1G.6, 1H.6, shaft heights 180 to 200 without regreasing device

No.	Designation
4.40	Cylindrical-roller bearing (floating bearing)
4.41.3	Deep-groove ball bearing (floating bearing)
4.46	Spring lock washer
4.47	Plain washer
4.63	Inner bearing cover

10.7.6 Rolling-contact bearing for 1G.6, 1H.6, shaft heights 180 to 200 without regreasing device, non-drive end

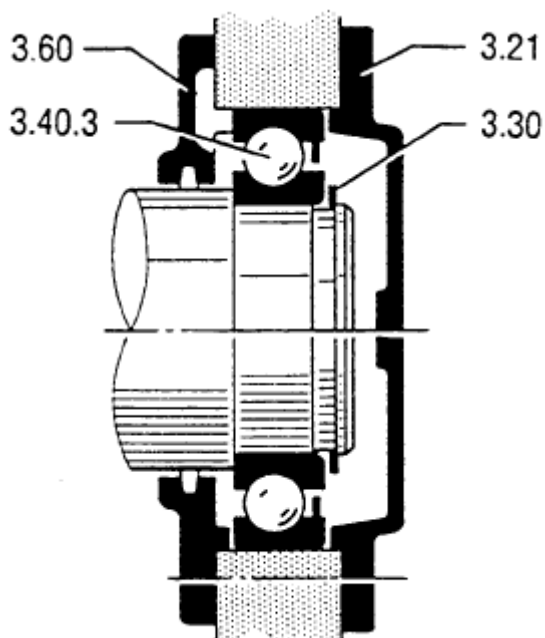

Locating bearing with one shaft extension

Table 10-9 Spare parts rolling-contact bearing for 1G.6, 1H.6, shaft heights 180 to 200 without regreasing device

No.	Designation	No.	Designation
3.21	Outer bearing cover (end cover)	3.40.3	Deep-groove ball bearing (locating bearing)
3.30	Locking ring	3.60	Inner bearing cover with felt rings

10.7.7 Rolling-contact bearing for 1G.6, 1H.6, shaft heights 180 to 200 with regreasing device, drive end

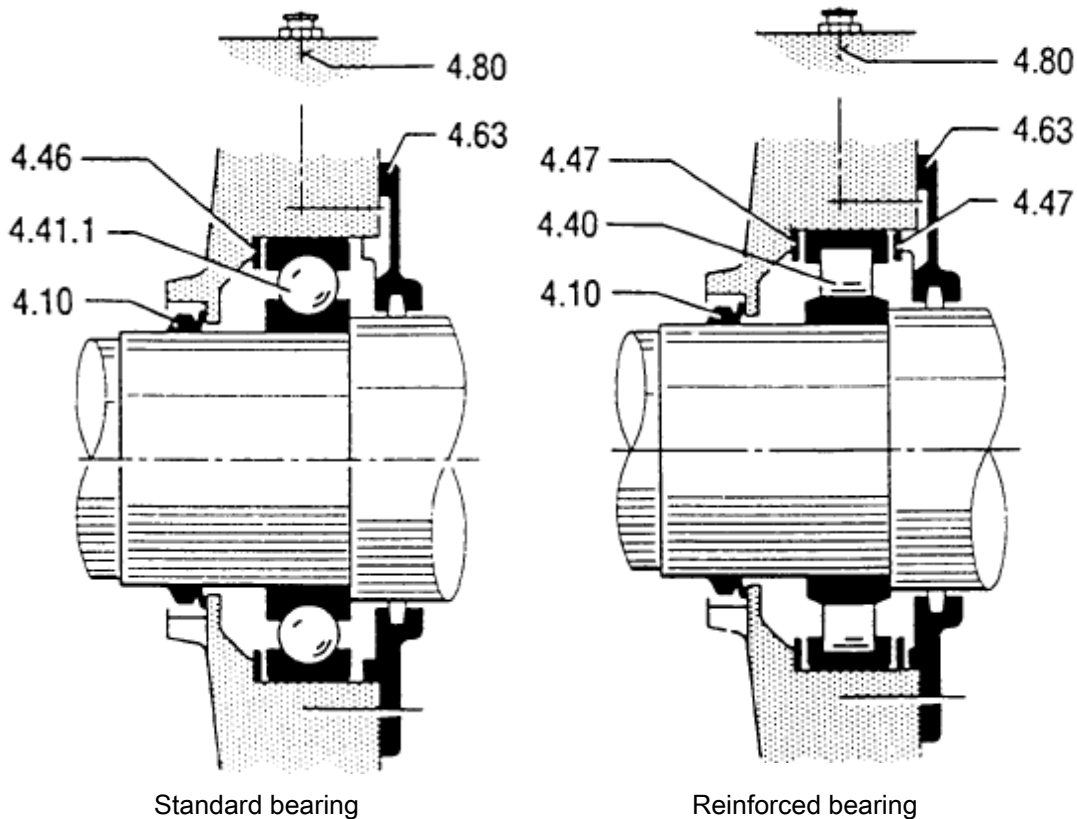
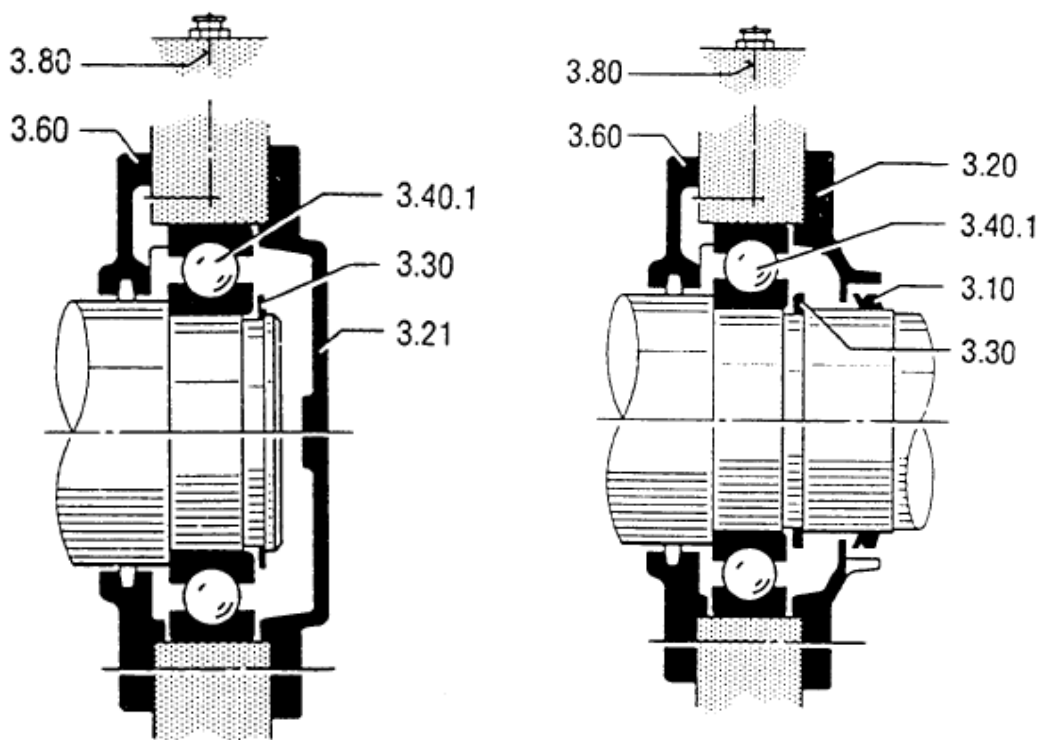

Table 10-10 Spare parts rolling-contact bearing for 1G.6, 1H.6, shaft heights 180 to 200 with regreasing device

No.	Designation	No.	Designation
4.10	Shaft sealing ring	4.47	Plain washer
4.40	Cylindrical-roller bearing (floating bearing)	4.63	Inner bearing cover with felt rings with shorter centering recess for floating bearing
4.41.1	Deep-groove ball bearing (floating bearing)	4.80	Grease nipple
4.46	Spring lock washer		

10.7.8 Rolling-contact bearing for 1G.6, 1H.6, shaft heights 180 to 200 with regreasing device, non-drive end



Locating bearing with one shaft extension

Locating bearing with two shaft extensions

Table 10-11 Spare parts rolling-contact bearing for 1G.6, 1H.6, shaft heights 180 to 200 with regreasing device

No.	Designation	No.	Designation
3.10	Shaft sealing ring	3.40.1	Deep-groove ball bearing (locating bearing)
3.20	Outer bearing cover	3.60	Inner bearing cover with felt rings
3.21	Outer bearing cover (end cover)	3.80	Grease nipple
3.30	Locking ring		

10.7.9 Rolling-contact bearing for 1G.6, 1H.6, shaft heights 225 to 280 with regreasing device, drive end

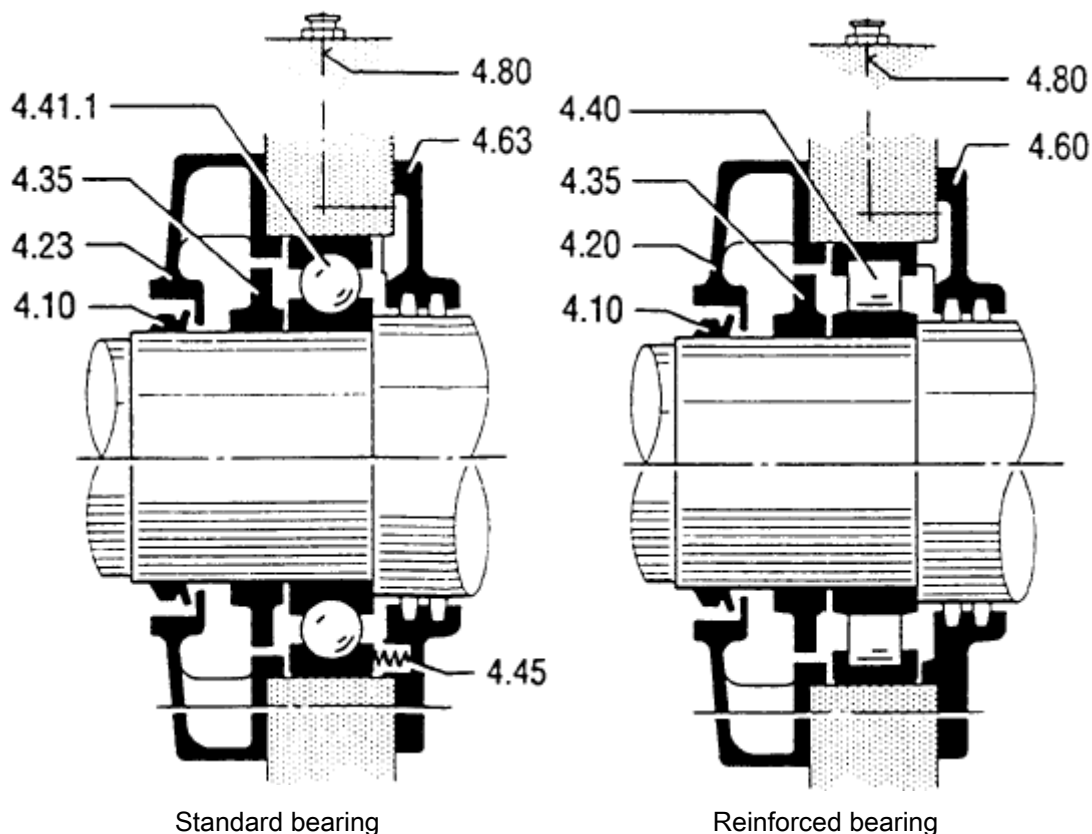
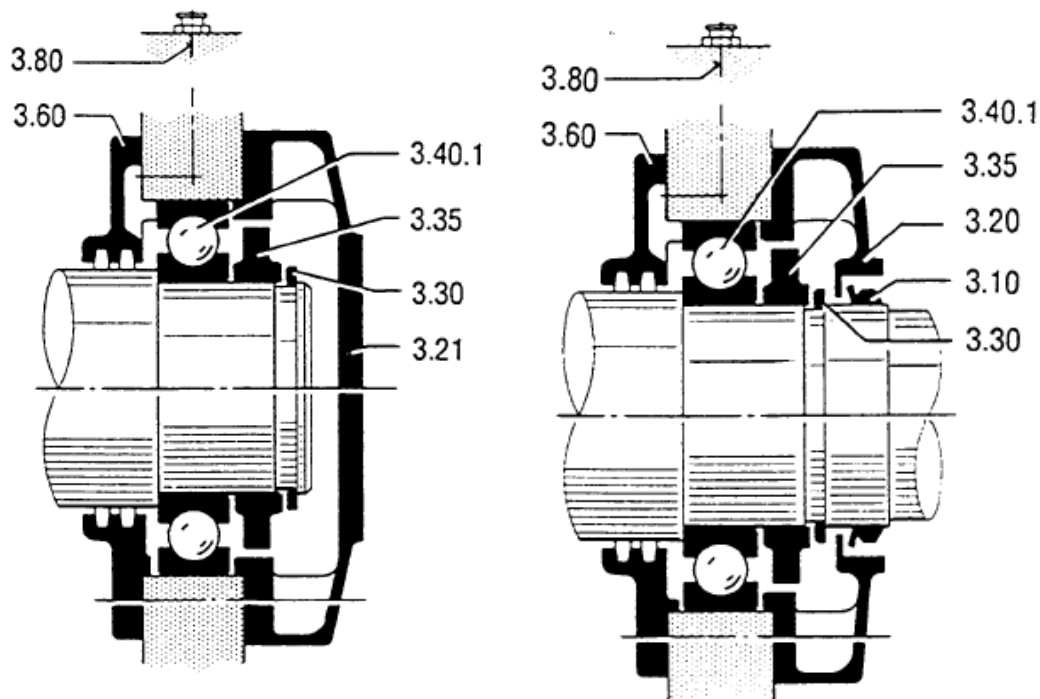

Table 10-12 Spare parts rolling-contact bearing for 1G.6, 1H.6, shaft heights 225 to 280 with regreasing device

No.	Designation
4.10	V ring
4.20	Outer bearing cover
4.23	Outer bearing cover with shorter centering recess for floating bearing
4.35	Grease slinger
4.40	Cylindrical-roller bearing (floating bearing)
4.41.1	Deep-groove ball bearing (floating bearing)
4.45	Compression spring
4.60	Inner bearing cover with felt rings
4.63	Inner bearing cover
4.80	Grease nipple

10.7.10 Rolling-contact bearing for 1G.6, 1H.6, shaft heights 225 to 280 with regreasing device, non-drive end



Locating bearing with one shaft extension

Locating bearing with two shaft extensions

Table 10-13 Spare parts rolling-contact bearing for 1G.6, 1H.6, shaft heights 225 to 280 with regreasing device

No.	Designation
3.10	V ring
3.20	Outer bearing cover
3.21	Outer bearing cover (end cover)
3.30	Locking ring
3.35	Grease slinger
3.40.1	Deep-groove ball bearing (locating bearing)
3.60	Inner bearing cover with felt rings
3.80	Grease nipple

10.7.11 Rolling-contact bearing seal 1G.6, 1H.6, 1G.7, 1H.7

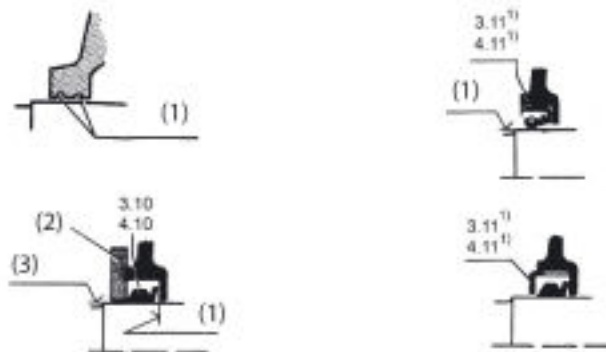

Image 10-8 Sealing for rolling-contact bearing for 1H.6, 1G.6

Table 10-14 Spare parts sealing for rolling-contact bearing for 1H.6, 1G.6

No.	Designation
3.10	V ring
4.10	V ring
3.11 ¹⁾	Radial shaft sealing ring, for special operating conditions only
4.11 ¹⁾	Radial shaft sealing ring, for special operating conditions only

10.8 Terminal boxes

10.8.1 Main terminal box gk 602 / gk 702

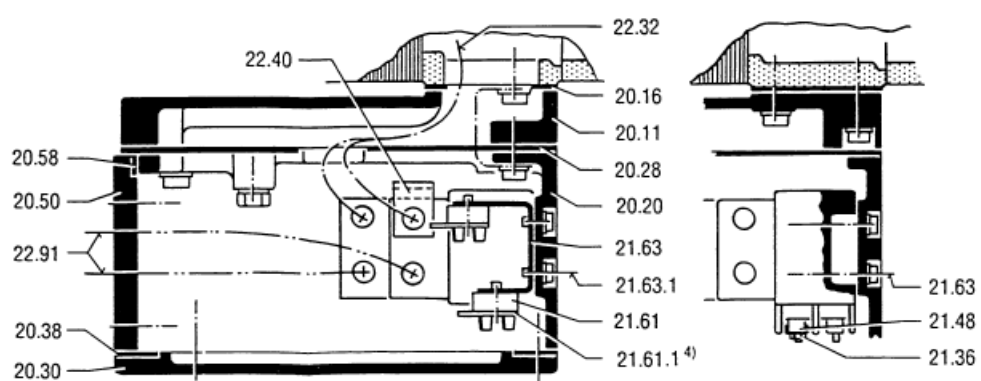
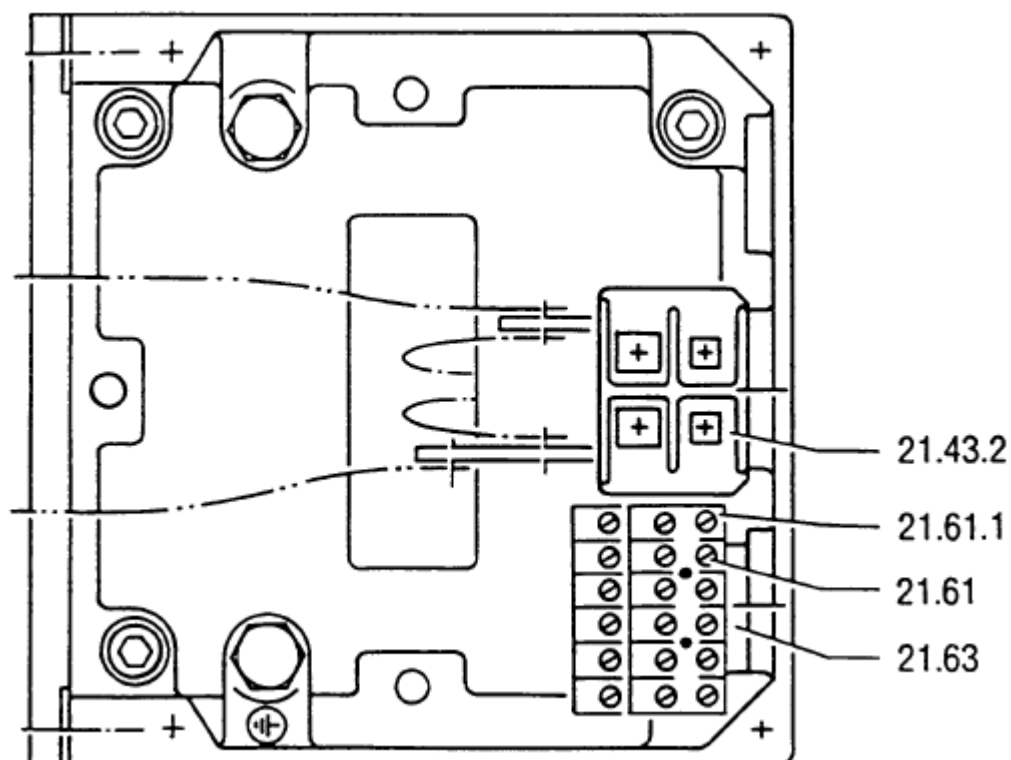

Image 10-9 Main terminal box gk 602 / 702

Table 10-15 Spare parts main terminal box gk 602 / 702

No.	Designation	No.	Designation
20.11	Intermediate plate	21.43.2	Terminal strip on right
20.16	Seal	21.48	Terminal clip
20.20	Terminal box casing	21.61	Terminal block
20.28	Seal	21.61.1	Set of labels
20.30	Cover	21.63	Bracket for terminal block
20.38	Seal	21.63.1	"Usit" washer
20.50	Entry plate	22.32	Winding supply
20.58	Seal	22.40	Terminal link
21.36	Special nut	22.91	External connecting lead

10.8.2 1XB7700 terminal box

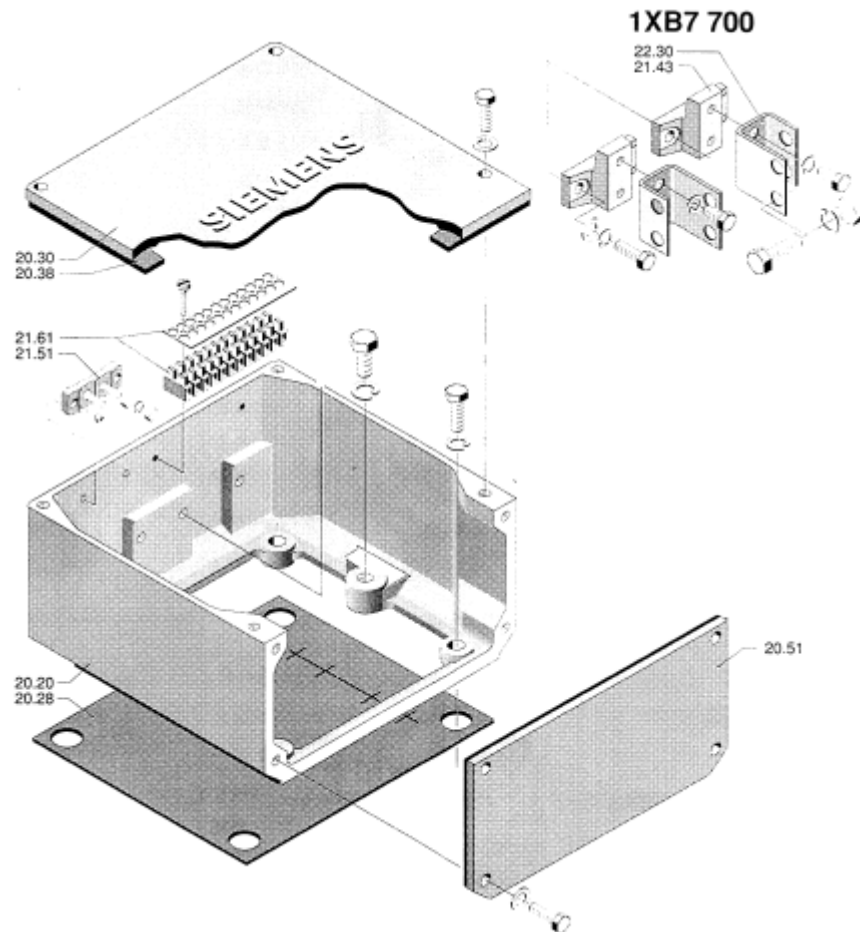

Image 10-10 1XB7700 main terminal box

Table 10-16 Spare parts main terminal box 1XB7700

No.	Designation
20.20	Housing
20.28	Seal
20.30	Cover
20.38	Seal
20.51	Entry plate
21.43	Post insulator
21.51	Terminal post insulator for auxiliary circuit
21.61	Terminal strip for auxiliary circuit
22.30	Connection busbar for power circuit

10.8.3 1XB7710 main terminal box

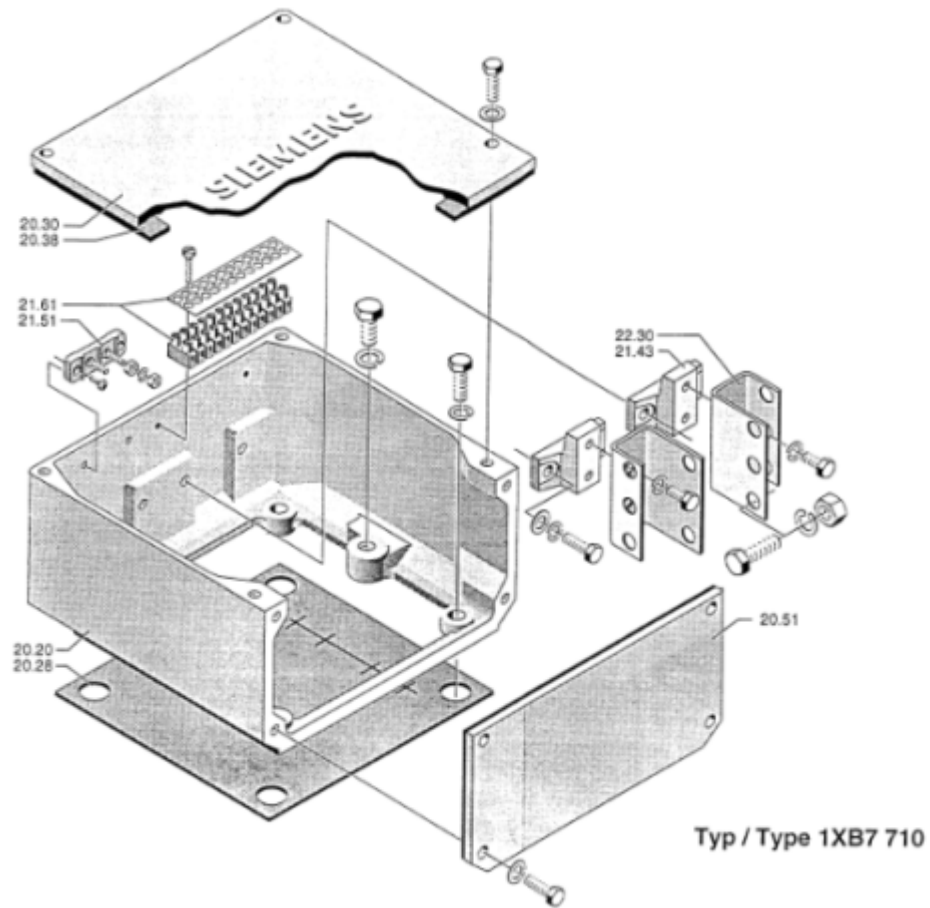

Image 10-11 Main terminal box 1XB7710

Table 10-17 Spare parts main terminal box 1XB7710

No.	Designation
20.20	Housing
20.28	Seal
20.30	Cover
20.38	Seal
20.51	Entry plate
21.43	Post insulator
21.51	Terminal block for auxiliary circuit
21.61	Terminal strip for auxiliary circuit
22.30	Connection busbar for power circuit

10.8.4 1XB7942 main terminal box

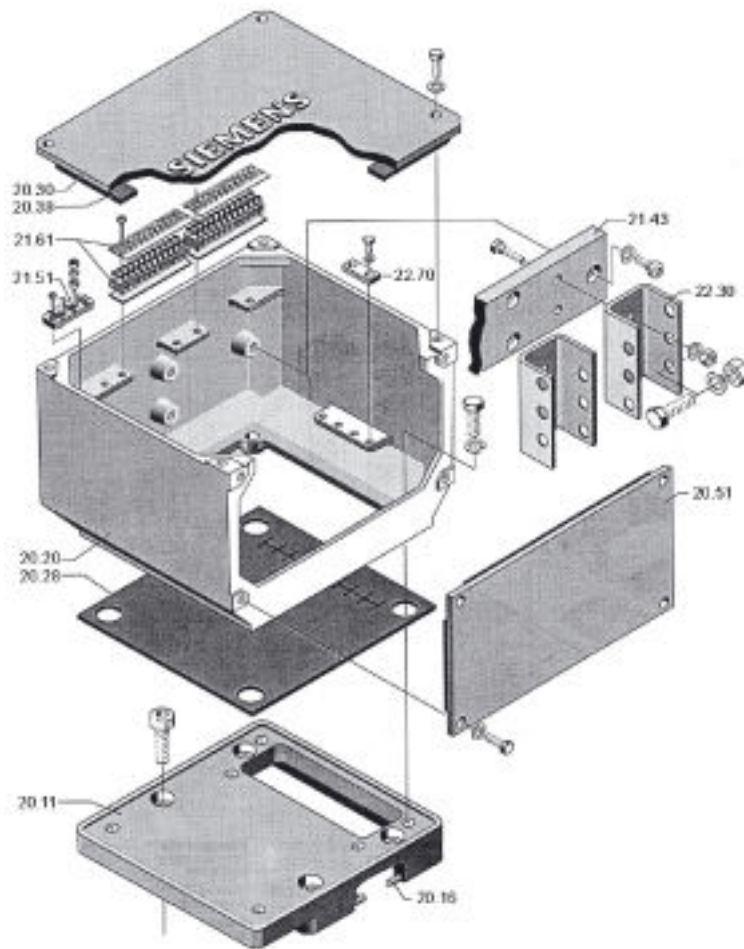

Image 10-12 Main terminal box 1XB7942

Table 10-18 Spare parts main terminal box 1XB7942

No.	Designation
20.11	Intermediate plate
20.16	Seal
20.20	Housing
20.28	Seal
20.30	Cover
20.38	Seal
20.51	Entry plate with seal
21.43	Post insulator
21.51	Terminal block for auxiliary circuit
21.61	Terminal strip for auxiliary circuits
22.30	Connection busbar for power circuit
22.70	Terminal strip for PE conductor

10.8.5 Auxiliary terminal box

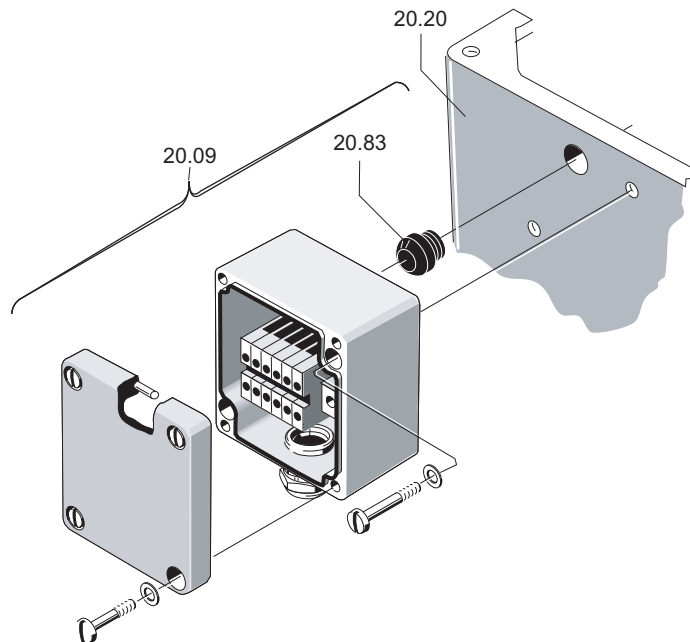

Image 10-13 Auxiliary terminal box

Table 10-19 Spare parts auxiliary terminal box

No.	Designation
20.09	Auxiliary terminal box
20.20	Housing
20.83	Rubber sleeve

10.9 Speed sensor

10.9.1 Shaft height 160

10.9.1.1 Speed sensor with conical hub

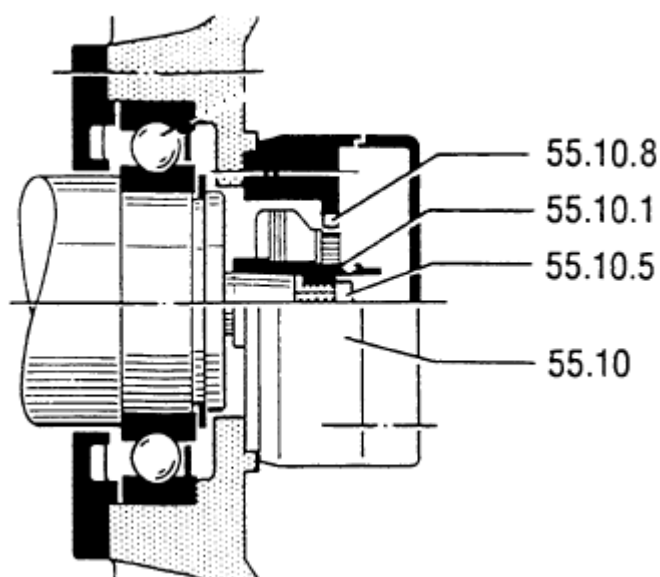

Image 10-14 Speed sensor with conical hub for shaft height 160

Table 10-20 Spare parts speed sensor with conical hub for shaft height 160

No.	Designation
55.10	Speed sensor
55.10.1	Speed sensor rotor
55.10.5	Fastening screw
55.10.8	Carbon brushes

See also

Speed sensor with conical hub (Page 99)

10.9.1.2 Speed sensor for overhung mounting

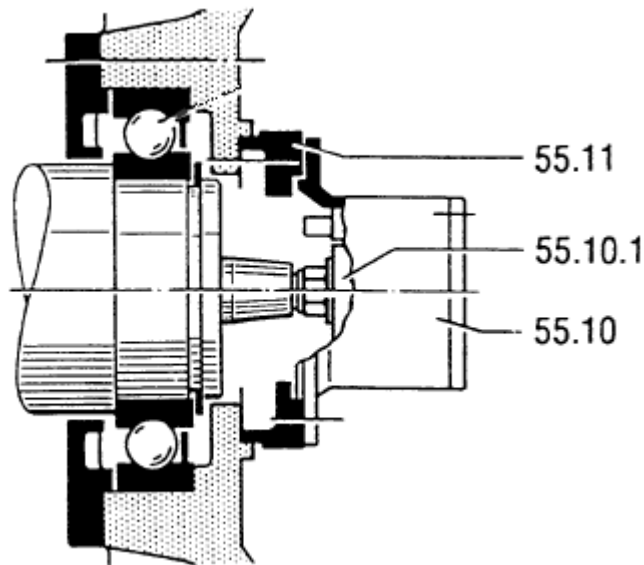

Image 10-15 Speed sensor for overhung mounting for shaft height 160

Table 10-21 Spare parts speed sensor for overhung mounting for shaft height 160

No.	Designation
55.10	Speed sensor
55.10.1	Speed sensor rotor
55.11	Adapter flange

See also

Speed sensor for overhung mounting (Page 100)

10.9.1.3 Speed sensor for construction type IM B5

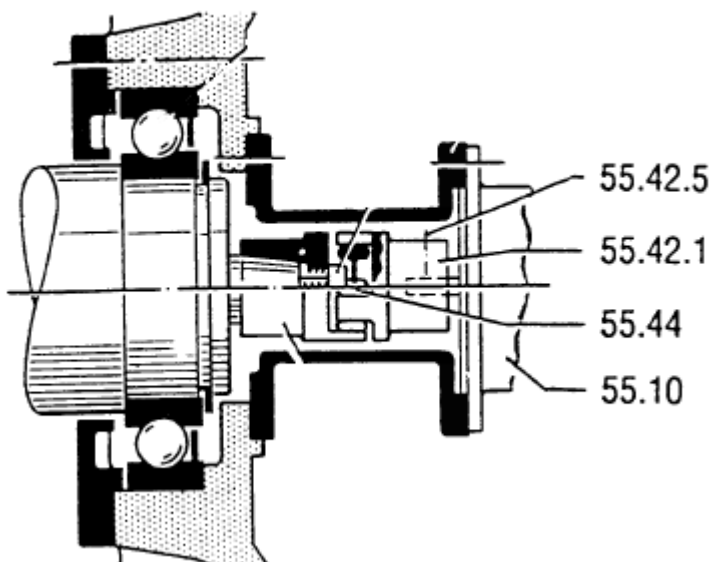

Image 10-16 Speed sensor for construction type IM B5 for shaft height 160

Table 10-22 Spare parts speed sensor for construction type IM B5 for shaft height 160

No.	Designation
55.10	Speed sensor
55.42.1	Speed-sensor-side half-couplings for cylindrical speed sensor shaft
55.42.5	Locking screw
55.44	Coupling star

See also

Speed sensor for construction type IM B5 (Page 102)

10.9.2 Shaft heights 180 to 630

10.9.2.1 Speed sensor with conical hub

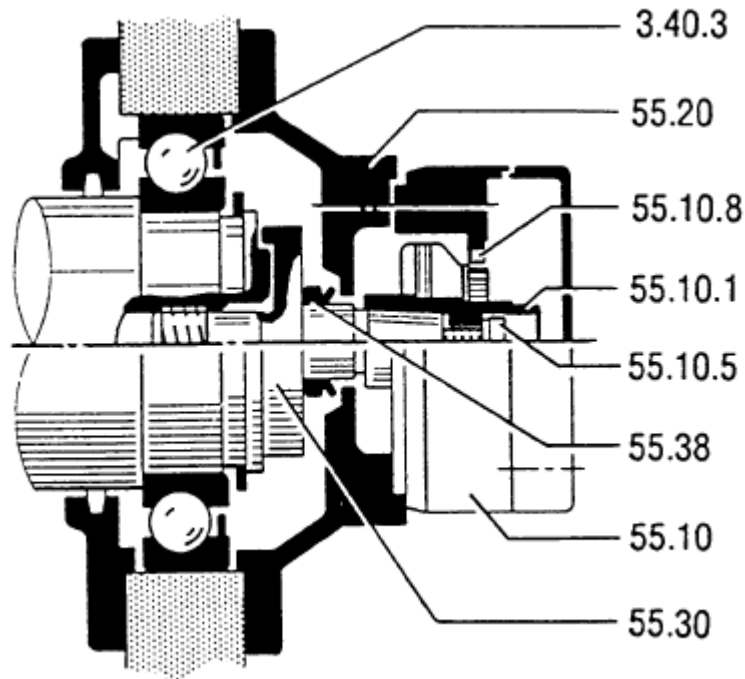

Image 10-17 Speed sensor with conical hub for shaft heights 180 to 630

Table 10-23 Spare parts speed sensor with conical hub for shaft heights 180 to 630

No.	Designation
55.10	Speed sensor
55.10.1	Speed-sensor rotor
55.10.5	Fastening screw
55.10.8	Carbon brushes
55.20	Bearing covers for speed sensor mounting
55.30	Threaded shaft journal with taper
55.38	V ring

See also

Speed sensor with conical hub (Page 99)

10.9.2.2 Speed sensor for overhung mounting

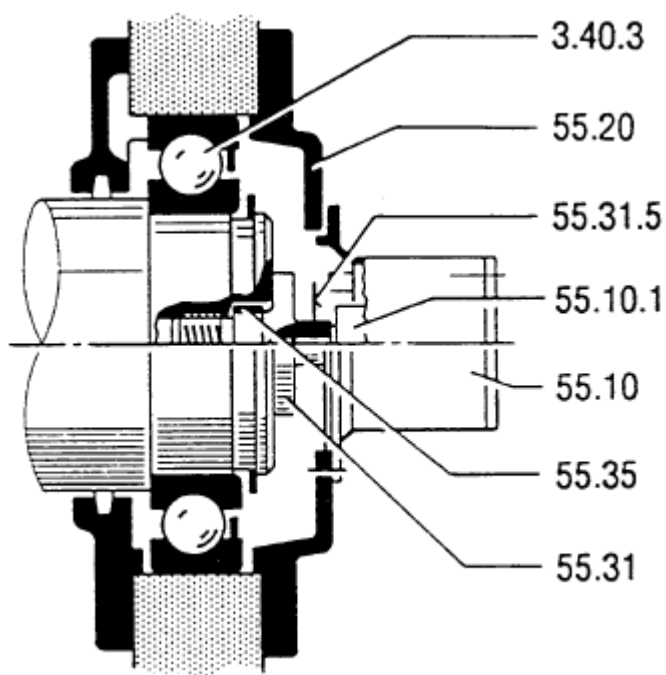

Image 10-18 Speed sensor for overhung mounting for shaft heights 180 to 630

Table 10-24 Spare parts speed sensor for overhung mounting for shaft heights 180 to 630

No.	Designation
55.10	Speed sensor
55.10.1	Speed-sensor rotor
55.20	Bearing covers for speed sensor mounting
55.31	Threaded shaft journal with cylindrical hole
55.31.5	Locking screw
55.35	Tolerance ring

See also

Speed sensor for overhung mounting (Page 100)

10.9.2.3 Speed sensor for construction type IM B5

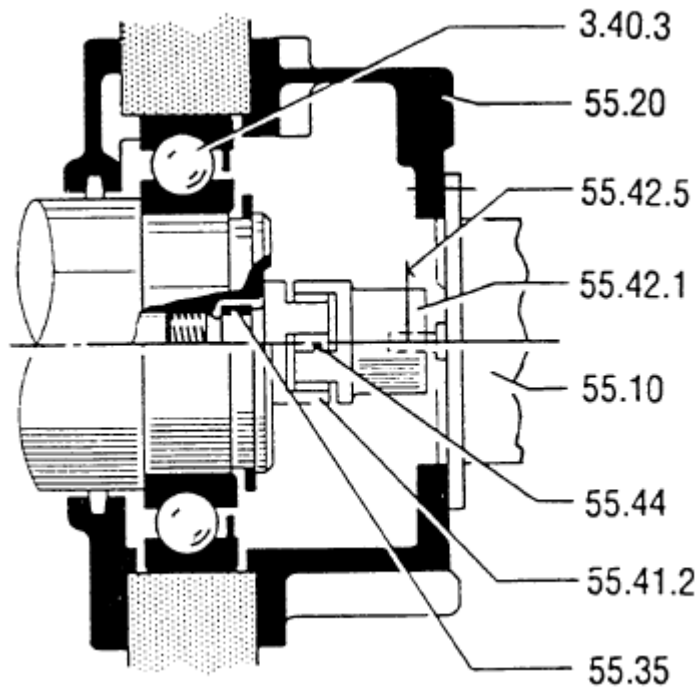

Image 10-19 Speed sensor for construction type IM B5 for shaft heights 180 to 630

Table 10-25 Spare parts speed sensor for construction type IM B5 for shaft heights 180 to 630

No.	Designation
55.10.	Speed sensor
55.20	Bearing covers for speed sensor mounting
55.35	Tolerance ring
55.42.1	Coupling halves at speed-sensor end for cylindrical speed-sensor shaft
55.42.5	Locking screw
55.44	Coupling star

See also

Speed sensor for construction type IM B5 (Page 102)

Disposal

11.1 Introduction

Protecting the environment and preserving its resources are corporate goals of the highest priority for us. Our worldwide environmental management system to ISO 14001 ensures compliance with legislation and sets high standards in this regard. Environmentally friendly design, technical safety and health protection are always firm goals even at the product development stage.

Recommendations for the environmentally friendly disposal of the machine and its components are given in the following section. Be sure to comply with local disposal regulations.

11.2 RoHS - restricting the use of certain hazardous substances

In compliance with RoHS ("Restriction of certain Hazardous Substances") we replace substances that are damaging to the environment by those that are not based on state-of-the-art technology. In doing so, safety in operation and handling will take priority at all times.

11.3 Country-specific legislation

Note

Country-specific legislation

When disposing of the machine or of waste that is created during the individual phases of its life cycle, please observe the statutory requirements applicable in the country of use.

11.4 Dismantling the machine

Dismantle the machine using the general procedures commonly used in mechanical engineering.



WARNING

Machine parts can fall

The machine is made up of heavy parts. These parts are liable to fall during dismantling. This can result in death, serious injury or material damage.

Before you release any machine parts, secure them so that they cannot fall.

11.5 Disposal of components

Components

The machines consist mainly of steel and various proportions of copper and aluminum. Metals are generally considered to be unlimitedly recyclable.

Sort the components for recycling according to whether they are:

- Iron and steel
- Aluminum
- Non-ferrous metal, e.g. windings
The winding insulation is incinerated during copper recycling.
- Insulating materials
- Cables and wires
- Electronic waste

Process materials and chemicals

Sort the process materials and chemicals for recycling according to whether they are for example:

- Oil
- Grease
- Cleaning substances and solvents
- Paint residues
- Anti-corrosion agent
- Coolant additives such as inhibitors, antifreeze or biocides

Dispose of the separated components according to local regulations or via a specialist disposal company. The same applies for cloths and cleaning substances which have been used while working on the machine.

Packaging material

- If necessary, contact a suitable specialist disposal company.
- Wooden packaging for sea transport consists of impregnated wood. Observe the local regulations.
- The foil used for water-proof packaging is an aluminum composite foil. It can be recycled thermally. Dirty foil must be disposed of via waste incineration.

Service and Support

Technical queries or additional information



If you have any technical queries or you require additional information, please contact Technical Support (<https://support.industry.siemens.com/cs/ww/en/sc/2090>).

Please have the following data ready:

- Type
- Serial number

You can find this data on the rating plate.

Contact person



If you wish to request on-site service or order spare parts, please contact your local office. This office will contact the responsible service center on your behalf. You can find your contact person in the relevant contact database:

www.siemens.com/yourcontact (www.siemens.com/yourcontact)

SIOS App



You can obtain optimum support everywhere using the SIOS App. The SIOS App is available for Apple iOS, Android and Windows phone.

Technical data and drawings

B.1 Tightening torques for screw and bolt connections

Bolt locking devices

- Refit nuts or bolts that are mounted together with locking, resilient, and/or force-distributing elements with identical, fully-functional elements when re-assembling. Always renew keyed elements.
- When screwing together threads secured with a liquid adhesive, use a suitable medium such as Loctite 243.
- Always use suitable securing devices or removable adhesives (e.g., Loctite 243) when installing fixing bolts with a clamping length of less than 25 mm. The clamping length is taken as the distance between the head of the bolt and the point at which the bolt is screwed in.

Tightening torques

The bolted connections with metal contact surfaces, such as end shields, bearing cartridge parts, terminal box parts bolted onto the stator frame, should be tightened to the following torques, depending on the thread size:

Table B-1 Tightening torques for screw/bolt connections with a tolerance of $\pm 10\%$

Case	M4	M5	M6	M8	M10	M12	M16	M20	M24	M30	M36	M42	M48	M56	
A	1.2	2.5	4	8	13	20	40	52	80	150	-	-	-	-	Nm
B	1.3	2.6	4.5	11	22	38	92	180	310	620	1080	1700	2600	4200	Nm
C	3	5	8	20	40	70	170	340	600	1200	2000	3100	4700	7500	Nm

Applications

The above-mentioned tightening torques apply for the following applications:

- Case A
Applies to electrical connections in which the permissible torque is normally limited by the bolt materials and/or the current carrying capacity of the insulators, with the exception of the busbar connections in case B.
- Case B
Applies to bolts screwed into components made from materials with lower property class (e. g. aluminum) and to bolts with property class 8.8 according to ISO 898-1.
- Case C
Applies to bolts with property class 8.8 or A4-70 according to ISO 898-1, however only to bolts screwed into components made from materials with higher property class, e.g. cast iron, steel or cast steel.

Note

Non-standard tightening torques

Different tightening torques for electrical connections and bolted connections for parts with flat seals or insulating parts are specified in the relevant sections and drawings.

Quality documents



You can find the quality documents here:

<https://support.industry.siemens.com/cs/ww/de/ps/13419/cert> (<https://support.industry.siemens.com/cs/ww/en/ps/13419/cert>)

Checklists

When carrying out any work on the machine, observe the general safety instructions (Page 15) and the specifications contained in EN 50110-1 regarding safe operation of electrical equipment.

D.1 Switching on

Table D-1 Items to check during switch-on

Items to check during switch-on	O.K.	Comment
Machine started without load for a short period "Start motor" Direction of rotation checked		
When running down from mechanical operation, noises and vibrations at the bearings and bearing shields checked.		
Machine started again and run up to maximum permissible speed - smooth running checked		
With machine running satisfactorily, cooling system switched on Machine monitored for a while in idling operation		
With satisfactory idling performance, load connected to machine Smooth running checked		
Values for voltage, current and output logged As far as possible, the corresponding values for the working machine are logged.		
Temperatures of the bearings, windings, etc., monitored and logged until the system reaches a steady state.		
Operating time reduced accordingly if the water-to-water cooler (if installed) is not operated at this "preliminary" dry run stage.		
Note:		
Date	Name	Signature

D.2 Commissioning

Table D-2 Items to check during commissioning

Items to check during commissioning	O. K.	Remark
The system is correctly installed		
The motor has been properly installed		
The control and speed monitoring systems are correctly designed and installed		
Suitable measures have been implemented for light-load duty ($I < 0.5 I_N$)	Yes/No	
The machine has been properly installed and aligned		
Output elements are in accordance with specifications with respect to axial position, alignment and balancing of couplings, etc.		
The minimum insulation resistance values are within tolerance		
The machine is connected up appropriately for the specified direction of rotation		
The grounding and equipotential bonding connections have been made correctly		
The rotor can spin without coming into contact with the stator		
The flow of cooling air is not impeded		
The carbon brushes and brush levers can move freely		
The spring pressure on all brush holders is identical		
All fixing screws, connecting elements and electrical connections are securely tightened		
The bearings have been relubricated		
The bearing insulation is not bridged		
Supplementary equipment such as temperature monitoring system, anti-condensation heating, etc. are connected and fully operational		
All protection measures have been taken to prevent accidental contact with moving or live parts		
If the second shaft extension has not been used, its feather key has been secured to prevent it from falling out		
All external fans are ready for operation and have been connected so that they rotate in the direction specified		
Brakes have been tested		
If an air-to-water heat exchanger is installed, the water cooler is connected, filled, air bled, and ready to run		
A test run has been carried out without water cooling where there has been a lengthy time delay between assembly and commissioning		
Note:		
Date	Name	Signature

D.3 Inspection at standstill

Table D-3 Items to inspect when machine is at standstill

Items to inspect when machine is at standstill	O.K.	Remarks
Commutator temperature measurement immediately after inspection opening has been opened		
Check on status of commutator, brush contact surface, oxide film formation		
Check on air gap between support and commutator		
Check on status of carbon brushes		
Brush holder correctly aligned and fastened		
Easy movement of brush pressure fingers		
Check on length of carbon brushes		
Check on easy movement of carbon in the support pockets		
Alignment of machine		
Electrical and mechanical connections securely tightened		
If present, bearing insulation OK		
Measurement of isolation resistance of field winding		
Measurement of isolation resistance of armature circuit		
Clean coal dust from machine		
Cleaning the cooling passages		
If heat exchanger is installed: filter change or filter cleaning		
Check bearing seals		
Operating hours		
Sealing of machine		
If heat exchanger is installed: Check heat exchanger seals		
Next recommended inspection date:		
Other remarks:		
Date	Name	Signature

D.4 Inspection when the motor is running

Table D-4 Items to inspect when the motor is running

Items to inspect when the motor is running	O.K.	Remarks
Speed and direction of rotation		
Winding temperature		
Coolant temperature		
Bearing temperature		
Average loading (armature current)		
Regreasing of bearings		
Bearing-housing vibrations, drive end, axial, radial, horizontal		
Bearing-housing vibrations, non-drive end, axial, radial, horizontal		
Smooth running and running noise of machine		
Commutation behavior (spark note)		
Next recommended inspection date:		
Other remarks:		
Date	Name	Signature

Index

A

- Air gap torques, 27
- Aligning, 45, 49
 - Accuracy, 50
 - Prerequisites, 39
- Ambient conditions, 22
- Anti-condensation heating
 - Insulation resistance, 38
- Applications, 21
- Armature circuit, 68, 72
- Assembly
 - Bolt locking elements, 97
 - Speed sensor, 98
 - Speed sensor for overhung mounting, 101
 - Speed sensor with conical hub, 99
- Auxiliary circuit, 23
 - Connection, 58
- Auxiliary circuits, 54
- Axial force, 50
- Axial gap, 48

B

- Balance quality, 42
- Bearing bushes
 - Drive end, 24
 - Non-drive end, 24
- Bearing seizure damage, 32
- Belt output, 51
- Belt tension, 51
- Bolt locking device, 139
- brush dust
 - Removal, 89
- Brush height, 89
- Brush holder, 91
- Brush monitoring, 59
- Brush replacement, 90
- Brush rocker, 91

C

- Cable entry, 53
- Carbon brushes, 89
 - Mounting, 90
 - Removal, 90

- Replacement, 90
 - Spare parts, 105
- Center of gravity, 29, 44
- Centering flange, 49
- Check list
 - Commissioning, 145
 - Inspection, 146
 - Switching on, 144
- Condensate, 72
- Connecting cables
 - Selection of, 53
- Connection, 54
 - with cable lugs, 55
 - without cable lugs, 56
- Converter, 64
- Cooling, 21, 51
- Cooling air, 51
- Cooling method, 21
- Cooling system
 - faults, 78
- Correct usage, 23
- Corrosion protection, 34
 - Removing, 41
- Cover sheet, 67

D

- Damage during transportation, 27
- Deactivating, 69
- Degree of protection, 22, 23, 45
- Delivery, 27
- Disassembly
 - Machine, 95
 - Speed sensor for overhung mounting, 100
 - Speed sensor with conical hub, 99
- Disconnecting wiring, 96
- Disposal
 - Chemicals, 136
 - Components, 136

E

- Electromagnetic compatibility, 19
- Electromagnetic fields, 20
- Emergency off, 73
- Emitted interference, 20
- Equipotential bonding, 58
 - Internal, 58

Equipotential bonding connection, 58
ESD guidelines, 18
External fan, 26, 51, 60
 Commissioning, 66

F

faults, 71
Faults, 78
 Brushes, 80
 Commutator, 81
 Cooling system, 78
 Inspection, 77
 Roller bearings, 79
Feather key, 43
Five safety rules, 15
Flammable substances, 17
Flange connection, 39
Follow-up inspection, 84

G

General inspection, 86
Geometry of the flange, 39
Grease types, 88
Grounding conductor, 57

H

Hazardous substances, 17
Hearing damage, 18, 25
Hot surfaces, 17

I

Initial inspection, 84
Inspection
 Faults, 77
Installation
 Speed encoder for type of construction
 IM B5, 102
Insulation class, 22
Insulation resistance, 36, 64, 75
 Anti-condensation heating, 38
 measure, 36
Interference immunity, 19
Interlocking circuit
 External fan, 26

L

Lifting, 29, 31, 44
Local service, 137
Long-term storage, 33
Low-Voltage Directive, 15

M

Machine
 Aligning to the driven machine, 47
 Assembly, 97
 Disassembly, 96
 Mounting, 47
 setting down, 45
Machine design, 22
Machine expansion, 48
Machine type, 105
Main circuit, 23
Maintenance
 Maintenance intervals, 83
Maintenance intervals, 86
Minimum radial forces, 65
More information, 137
Mounting, 50
Mounting parts, 35
Mounting-foot hole dimensions, 39

N

Natural installation frequency, 72
Neutral zone, 96
Noise emissions, 18, 25

O

Operating mode, 25
Operating under light-load conditions, 76
Output element, 42
Overspeed, 25, 68, 72

P

Paint system, 94
Paintwork damage, 94
Periods of non-operation
 Decommissioning, 74
 Lubricating before commissioning, 74
 Shaft grounding device, 74

Pipe connection, 51
 Polarization index, 36, 38, 64, 75
 Positioning, 47
 Precision alignment, 48
 Preparations for assembly, 35
 Property class, 47
 Protective circuit, 60

Q

Qualified personnel, 16

R

Radial force, 50
 Rating plate, 23
 Re-commissioning, 76
 Regreasing, 73, 87
 Regreasing intervals, 88
 Removal
 Speed encoder for type of construction
 IM B5, 102
 Removing the machine, 96
 Residual risks, 25
 Restriction of certain Hazardous Substances, 135
 Risk of explosion, 21
 RoHS, 135
 Roller bearings
 faults, 79
 Regreasing, 65
 Rolling-contact bearing, 24
 Assembly, 98
 Disassembly, 97
 Replacement, 106
 Sealing, 98
 Rotating parts, 17
 Rotor
 attach, 95
 Rotor shipping brace, 28, 40
 Remove, 40
 rotors
 attach, 96

S

Safety instructions
 Flammable substances, 17
 Hazardous substances, 17
 Hot surfaces, 17
 Live parts, 16

Maintenance work, 83
 Rotating parts, 17
 Sealing, 97
 Selection of bolts, 47
 Serial number, 105
 Shaft assembly, 27
 Spare parts, 137
 Auxiliary terminal box, 128
 External fan, 111
 Main terminal box, 124, 125, 126, 127
 Ordering, 106
 Rolling-contact bearing, 112, 113, 114, 115, 116,
 117, 118, 119, 120, 121
 Rolling-contact seal, 122
 Speed sensor, 129, 130, 131, 132, 133, 134
 Stator and rotor, 108, 110
 Terminal box, 105
 Spare parts ordering, 105
 Spares on Web, 106
 Speed sensor, 59
 Standard flange, 49
 Standstill, 76
 Stator winding
 Temperature monitoring, 60
 Stoppages, 73
 Roller bearings, 75
 Storage, 33
 Storage location, 33
 Surface of the foundations, 39
 System resonances, 26
 System-inherent frequencies, 26

T

Technical Support, 137
 Temperature monitoring, 59
 Stator winding, 60
 Terminal box, 23, 54
 Terminal designation, 54
 Terminal diagram, 54
 Tightening torques
 Bolted connection, 139
 Torsional loadings, 27
 Transporting, 29, 31, 44
 Turning the machine on to its side, 40
 Type of balancing, 42

V

Vibration magnitudes, 72
 Vibration values, 26

W

Wall face, 39

Wall mounting, 39

Water drain holes, 45

Siemens AG
Process Industries and Drives
Postfach 48 48
90026 NÜRNBERG
GERMANY

www.siemens.com/drives